

---

# Datasheet for Telink BLE SoC TLSR8250F512

DS-TLSR8250-E2

Ver 0.8.1

---

2019/1/23

**Keyword:**

Bluetooth Low Energy; Tmall Genie Mesh; Features;  
Package; Pin layout; Memory; MCU; Working modes;  
Wakeup sources; RF Transceiver; Clock; Timers;  
Interrupt; Interface; PWM; ADC; Temperature sensor;  
AES; Electrical specification

**Brief:**

This datasheet is dedicated for Telink BLE SoC  
TLSR8250F512 (VID: 0x03). In this datasheet, key  
features, working mode, main modules, electrical  
specification and application of the TLSR8250F512 are  
introduced.



**Published by**  
**Telink Semiconductor**

**Bldg 3, 1500 Zuchongzhi Rd,**  
**Zhangjiang Hi-Tech Park, Shanghai, China**

**© Telink Semiconductor**  
**All Right Reserved**

### **Legal Disclaimer**

Telink Semiconductor reserves the right to make changes without further notice to any products herein to improve reliability, function or design. Telink Semiconductor disclaims any and all liability for any errors, inaccuracies or incompleteness contained herein or in any other disclosure relating to any product.

Telink Semiconductor does not assume any liability arising out of the application or use of any product or circuit described herein; neither does it convey any license under its patent rights, nor the rights of others

The products shown herein are not designed for use in medical, life-saving, or life-sustaining applications. Customers using or selling Telink Semiconductor products not expressly indicated for use in such applications do so entirely at their own risk and agree to fully indemnify Telink Semiconductor for any damages arising or resulting from such use or sale.

### **Information:**

For further information on the technology, product and business term, please contact Telink Semiconductor Company ([www.telink-semi.com](http://www.telink-semi.com)).

For sales or technical support, please send email to the address of:

[telinknsales@telink-semi.com](mailto:telinknsales@telink-semi.com)

[telinknsupport@telink-semi.com](mailto:telinknsupport@telink-semi.com)

**Revision History**

<b>Version</b>	<b>Major Changes</b>	<b>Date</b>	<b>Author</b>
0.8.0	Preliminary release	2019/1	CJH, SY, HZF, Cynthia
0.8.1	Updated section 1.4 Ordering information	2019/1	LWT, Cynthia

## 1 Table of contents

1	Overview .....	7
1.1	Block diagram .....	7
1.2	Key features .....	8
1.2.1	General features .....	8
1.2.2	RF Features .....	9
1.2.3	Features of power management module.....	9
1.2.5	Flash features .....	10
1.4	Ordering information .....	10
1.5	Package .....	11
1.6	Pin layout .....	13
1.6.1	Pin layout for TLSR8250F512ET32 .....	13
1.6.2	Pin layout for TLSR8250F512ES16 .....	15
1.6.3	Notes.....	16
2	Memory and MCU .....	17
2.1	Memory .....	17
2.1.1	SRAM/Register.....	17
2.1.2	Flash.....	19
2.1.3	E-Fuse .....	19
2.2	Firmware encryption .....	19
2.3	MCU .....	20
2.4	Working modes.....	20
2.5	Reset .....	22
2.6	Power Management .....	23
2.6.1	Power-On-Reset (POR) and Brown-out detect.....	23
2.6.2	Working mode switch.....	26
2.6.3	LDO and DCDC .....	27
2.6.4	VBAT and VANT power-supply mode .....	27
2.7	Wakeup sources .....	28
2.7.1	Wakeup source – 32kHz timer .....	28
2.7.2	Wakeup source – IO .....	28
2.7.3	Register table.....	29
3	BLE/2.4GHz RF Transceiver .....	30
3.1	Block diagram .....	30
3.2	Air interface data rate and RF channel frequency .....	31
3.3	Baseband .....	31
3.3.1	Packet format .....	31
3.3.2	RSSI and frequency offset.....	31
4	Clock .....	32
4.1	Clock sources .....	32

4.2	System clock .....	32
4.3	Module clock .....	33
4.3.1	System Timer clock .....	33
4.4	Register table .....	33
5	Timers .....	35
5.1	Timer0~Timer2 .....	35
5.1.1	Register table .....	35
5.1.2	Mode0 (System Clock Mode) .....	36
5.1.3	Mode1 (GPIO Trigger Mode) .....	36
5.1.4	Mode2 (GPIO Pulse Width Mode) .....	37
5.1.5	Mode3 (Tick Mode) .....	38
5.1.6	Watchdog .....	38
5.2	32K LTIMER .....	39
5.3	System Timer .....	39
6	Interrupt System .....	41
6.1	Interrupt structure .....	41
6.2	Register configuration .....	41
6.2.1	Enable/Mask interrupt sources .....	42
6.2.2	Interrupt mode and priority .....	43
6.2.3	Interrupt source flag .....	43
7	Interface .....	44
7.1	GPIO .....	44
7.1.1	Basic configuration .....	44
7.1.1.1	GPIO lookup table .....	44
7.1.1.2	Multiplexed functions .....	46
7.1.1.3	Drive strength .....	47
7.1.2	Connection relationship between GPIO and related modules .....	48
7.1.3	Pull-up/Pull-down resistor .....	50
7.2	SWM and SWS .....	51
7.3	I2C .....	52
7.3.1	Communication protocol .....	52
7.3.2	Register table .....	52
7.3.3	I2C Slave mode .....	53
7.3.3.1	DMA mode .....	54
7.3.3.2	Mapping mode .....	55
7.3.4	I2C Master mode .....	55
7.3.4.1	I2C Master Write transfer .....	56
7.3.4.2	I2C Master Read transfer .....	56
7.3.5	I2C and SPI Usage .....	56
7.4	SPI .....	57
7.4.1	Register table .....	57
7.4.2	SPI Master mode .....	57

7.4.3	SPI Slave mode .....	58
7.4.4	I2C and SPI Usage .....	59
7.5	UART .....	59
8	PWM.....	62
8.1	Register table.....	62
8.2	Enable PWM .....	65
8.3	Set PWM clock.....	65
8.4	PWM waveform, polarity and output inversion .....	66
8.4.1	Waveform of signal frame .....	66
8.4.2	Invert PWM output.....	66
8.4.3	Polarity for signal frame .....	66
8.5	PWM mode.....	67
8.5.1	Select PWM mode .....	67
8.5.2	Continuous mode .....	67
8.5.3	Counting mode .....	68
8.5.4	IR mode.....	68
8.5.5	IR FIFO mode .....	69
8.5.6	IR DMA FIFO mode .....	70
8.6	PWM interrupt.....	74
9	SAR ADC.....	75
9.1	Power on/down .....	75
9.2	ADC clock .....	75
9.3	ADC control in auto mode .....	76
9.3.1	Set max state and enable channel.....	76
9.3.2	“Set” state.....	76
9.3.3	“Capture” state.....	77
9.3.4	Usage cases.....	78
9.3.4.1	Case 1: 4-channel sampling for random number, Left, Right and Misc 78	
9.3.4.2	Case 2: 3-channel sampling for random number, Left and Misc.....	78
9.3.4.3	Case 3: 3-channel sampling for Left, Right and Misc.....	78
9.3.4.4	Case 4: 3-channel sampling for random number, Left and Right .....	79
9.3.4.5	Case 5: 2-channel sampling for Left and Misc.....	79
9.3.4.6	Case 6: 2-channel sampling for random number and Left .....	79
9.3.4.7	Case 7: 2-channel sampling for random number and Misc.....	80
9.3.4.8	Case 8: 2-channel sampling for Left and Right .....	80
9.3.4.9	Case 9: 1-channel sampling for Left .....	80
9.3.4.10	Case 10: 1-channel sampling for Misc .....	80
9.3.4.11	Case 11: 1-channel sampling for RNG .....	81
9.3.4.12	Case 12 with detailed register setting .....	81
9.4	Register table.....	83
10	Temperature Sensor.....	89

---

11	AES.....	91
11.1	RISC mode.....	91
11.2	DMA mode.....	91
11.3	AES-CCM .....	91
11.4	Register table.....	92
12	Key Electrical Specifications .....	93
12.1	Absolute maximum ratings.....	93
12.2	Recommended operating condition.....	93
12.3	DC characteristics .....	94
12.4	AC characteristics .....	94
12.5	SPI characteristics.....	97
12.6	I2C characteristics.....	98
12.7	Flash characteristics .....	99
13	Reference Design .....	101
13.1	Application example for TLSR8250F512ET32 .....	101
13.1.1	Schematic .....	101
13.1.2	BOM (Bill of Material).....	101
13.2	Application example for TLSR8250F512ES16.....	102
13.2.1	Schematic .....	102
13.2.2	BOM (Bill of Material).....	103

## 1 Overview

The TLSR8250F512 is Telink-developed Bluetooth LE SoC solution with internal Flash and it's dedicated for Tmall Genie. It's completely RoHS-compliant and 100% lead (Pb)-free.

The TLSR8250F512 combines the radio frequency (RF), digital processing, protocols stack software and profiles for Bluetooth Low Energy (up to Bluetooth 5) and Tmall Genie Mesh into a single SoC. The TLSR8250F512's embedded 512kB FLASH enables dynamic stack and profile configuration, and the final end product functionality is configurable via software, providing ultimate flexibility. The TLSR8250F512 also has hardware OTA upgrades support and multiple boot switching, allowing convenient product feature roll outs and upgrades.

The TLSR8250F512 integrates hardware acceleration to support the complicated security operations required by Bluetooth 4.2 and above standards without the requirement for an external DSP, thereby significantly reducing the product eBOM.

The TLSR8250F512 includes a full range of on-chip peripherals for interfacing with external components such as LEDs, sensors, touch controllers, keyboards, and motors.

### 1.1 Block diagram

The TLSR8250F512 is designed to offer high integration, ultra-low power application capabilities. The system's block diagram is as shown in Figure 1-1.

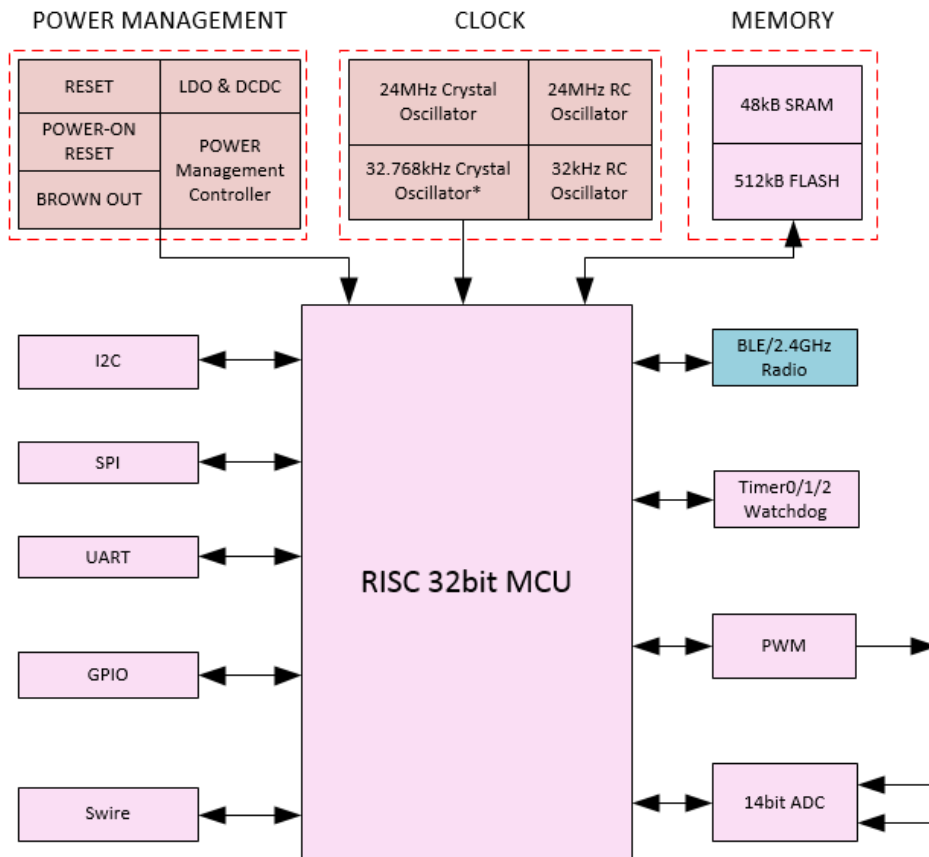

Figure 1- 1 Block diagram of the system



**\*Notes:**

- 1) Modules marked with different colors belong to different power domains. Power state of each power domain can be controlled independent of other power domains, for example, the BLE Radio module can be independently powered on or powered down irrespective of other modules such as power management module, clock, and etc.
- 2) The BLE/2.4GHz Radio is powered down by default.
- 3) The power management module and clock should be always powered on, even in deep sleep.
- 4) In deep sleep, except for the power management and clock, all other modules should be powered down.
- 5) The 32kHz crystal oscillator is only optional for the TLSR8250F512ET32 package.

The TLSR8250F512 integrates a power-balanced 32-bit MCU, BLE/2.4GHz Radio, 48kB SRAM, 512kB internal Flash, 14bit ADC, 6-channel PWM (1-channel IR/IR FIFO/IR DMA FIFO) and flexible GPIO interfaces.

The TLSR8250F512 also includes multi-stage power management design allowing ultra-low power operation and making it the ideal candidate for power-constraint applications.

With the high integration level of TLSR8250F512, few external components are needed to satisfy customers' ultra-low cost requirements.

## 1.2 Key features

### 1.2.1 General features

General features are as follows:

- 1) 4-byte Chip UID (Unique ID).
- 2) Embedded 32-bit proprietary microcontroller.
  - ✧ Better power-balanced performance than ARM M0
  - ✧ Instruction cache controller
  - ✧ Maximum running speed up to 48MHz
- 3) Program memory: internal 512kB Flash.
- 4) Data memory: 48kB on-chip SRAM, including up to 32kB SRAMs with retention in deep sleep, and one 16kB SRAM without retention in deep sleep.
- 5) RTC and other timers:
  - ✧ Clock source of 32.768kHz (only for QFN32 package) & 24MHz Crystal and 32kHz/24MHz embedded RC oscillator
  - ✧ Three general 32-bit timers with four selectable modes in active mode
  - ✧ Watchdog timer
  - ✧ A low-frequency 32kHz timer available in low power mode

- 6) A rich set of I/Os:
  - ✧ Up to 17/4 GPIOs depending on package option. All digital IOs can be used as GPIOs.
  - ✧ SPI.
  - ✧ I2C.
  - ✧ UART with hardware flow control support.
  - ✧ Swire debug Interface.
- 7) Up to 6 channels of differential PWM:
  - ✧ PWM1~PWM5: 5-channel normal PWM output.
  - ✧ PWM0: 1 channel with IR/IR FIFO/IR DMA FIFO mode for IR generation.
- 8) Sensor:
  - ✧ 14bit 6-channel (only GPIO input) SAR ADC
  - ✧ Temperature sensor
- 9) Embedded hardware AES and AES-CCM.
- 10) Embedded hardware acceleration for Elliptical curve cryptography (ECC) used in BLE4.2 and above and above.
- 11) Operating temperature: -40°C~+85°C
- 12) Supports BLE and Tmall Genie Mesh into a single SoC without the requirement for an external DSP.

### 1.2.2 RF Features

RF features include:

- 1) BLE/2.4GHz RF transceiver embedded, working in worldwide 2.4GHz ISM band.
- 2) Bluetooth 5 Compliant, 1Mbps, support Tmall Genie Mesh.
- 3) Rx Sensitivity: -96dBm@BLE 1Mbps.
- 4) Tx output power: up to +10dBm.
- 5) Single-pin antenna interface.
- 6) RSSI monitoring with +/-1dB resolution.
- 7) Auto acknowledgement, retransmission and flow control.

### 1.2.3 Features of power management module

Features of power management module include:

- 1) Power supply: 1.8V~3.6V (QFN32 package) / 2.7V~3.6V (TSSOP16 package).
- 2) Embedded LDO and DCDC.
- 3) Battery monitor: Supports low battery detection.

- 4) Multiple stage power management to minimize power consumption.
- 5) Low power consumption:
  - ✧ Whole Chip RX mode: 5.3mA
  - ✧ Whole Chip TX mode: 4.8mA @ 0dBm with DCDC
  - ✧ Deep sleep with external wakeup (without SRAM retention): 0.4uA
  - ✧ Deep sleep with SRAM retention: 1uA (with 8kB SRAM retention), 1.2uA (with 16kB SRAM retention), 1.4uA (with 32kB SRAM retention)

### 1.2.5 Flash features

The TLSR8250F512 embeds Flash with features below:

- 1) Total 512kB (4Mbits).
- 2) Flexible architecture: 4kB per Sector, 64kB/32kB per block.
- 3) Up to 256 Bytes per programmable page.
- 4) Write protect all or portions of memory.
- 5) Sector erase (4kB).
- 6) Block erase (32kB/64kB).
- 7) Cycle Endurance: 100,000 program/erases.
- 8) Data Retention: typical 20-year retention.
- 9) Multi firmware encryption methods for anti-cloning protection.

## 1.4 Ordering information

Table 1- 1 Ordering information of the TLSR8250F512\*1

Product Series	Package Type	Temperature Range	Product Part No.	Packing Method*2	Minimum Order Quantity
TLSR8250F512	32-pin TQFN 5x5x0.75mm	-40°C~+85°C	TLSR8250F512ET32	TR	3000
	16-pin TSSOP16 4.96x6.4x1.2mm	-40°C~+85°C	TLSR8250F512ES16	TR	5000

<sup>1</sup> MSL (Moisture Sensitivity Level): The 8250 series is applicable to MSL3 (Based on JEDEC Standard J-STD-020).

- ✧ After the packing opened, the product shall be stored at <30°C/ <60%RH and the product shall be used within 168 hours.
- ✧ When the color of the indicator in the packing changed, the product shall be baked before soldering.
- ✧ If baking is required, please refer to IPC/JEDEC J-STD-033 for baking procedure.

<sup>2</sup> Packing method "TR" means tape and reel. The tape and reel material DO NOT support baking under high temperature.

1.5 Package

Package dimensions for the TLSR8250F512ET32 and TLSR8250F512ES16 are shown as below.

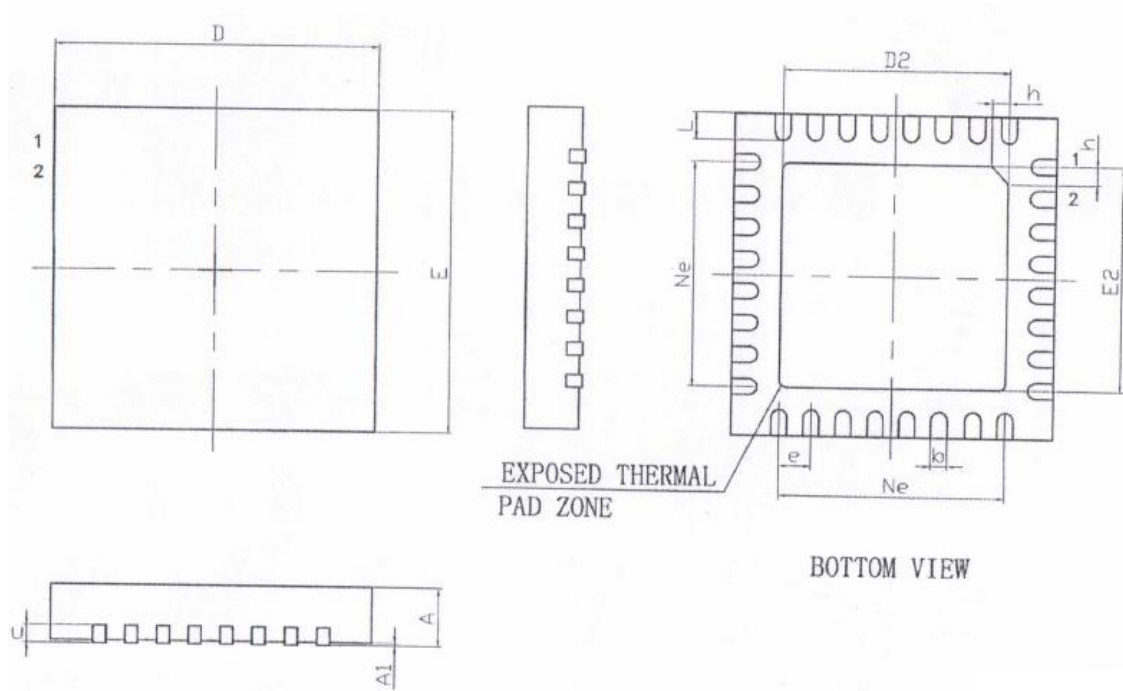

SYMBOL	MILLIMETER		
	MIN	NOM	MAX
A	0.70	0.75	0.80
A1	—	0.02	0.05
b	0.18	0.25	0.30
c	0.18	0.20	0.25
D	4.90	5.00	5.10
D2	3.40	3.50	3.60
e	0.50BSC		
Ne	3.50BSC		
E	4.90	5.00	5.10
E2	3.40	3.50	3.60
L	0.35	0.40	0.45
h	0.30	0.35	0.40
L/F载体尺寸	150x150	130x130	

**L/F carrier size**

Figure 1-2 Package dimension for TLSR8250F512ET32 (Unit: mm)

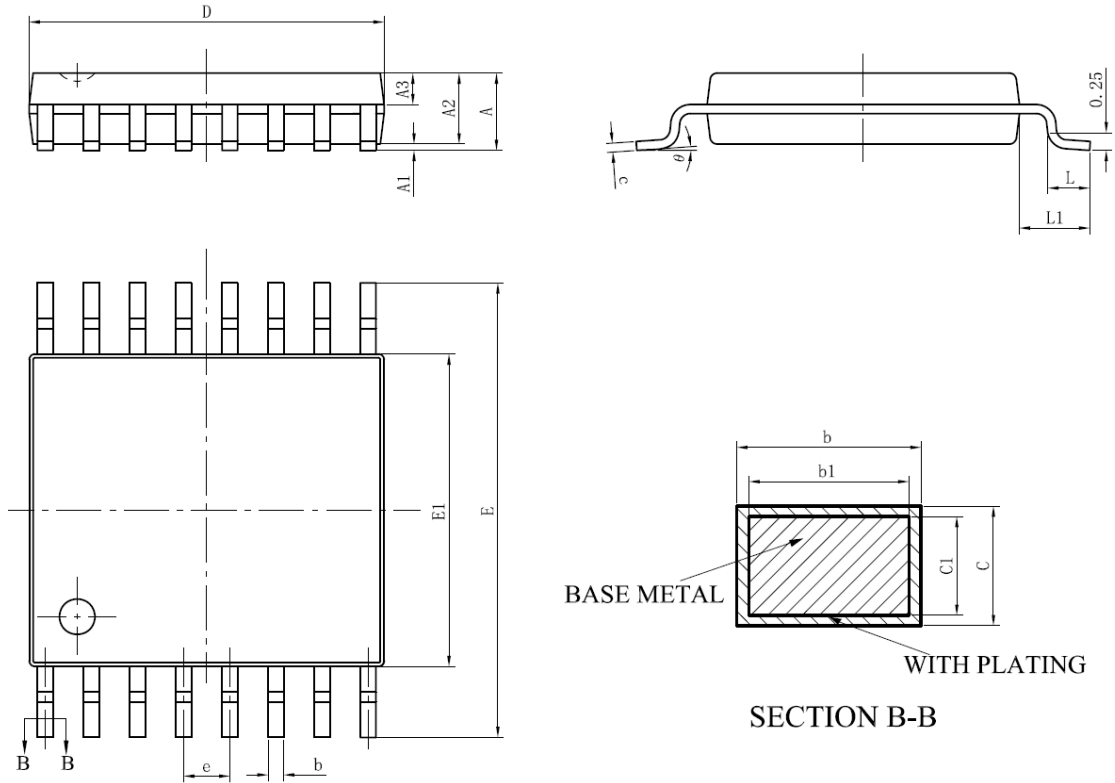

SYMBOL	MILLIMETER		
	MIN	NOM	MAX
A	—	—	1.20
A1	0.05	—	0.15
A2	0.90	1.00	1.05
A3	0.39	0.44	0.49
b	0.20	—	0.29
b1	0.19	0.22	0.25
c	0.13	—	0.18
c1	0.12	0.13	0.14
D	4.86	4.96	5.06
E	6.20	6.40	6.60
E1	4.30	4.40	4.50
e	0.65BSC		
L	0.45	0.60	0.75
L1	1.00BSC		
$\theta$	0	—	8°

Figure 1- 3 Package dimension for TLSR8250F512ES16 (Unit: mm)

### 1.6 Pin layout

#### 1.6.1 Pin layout for TLSR8250F512ET32

Figure 1- 4 shows pin assignment for the TLSR8250F512ET32.

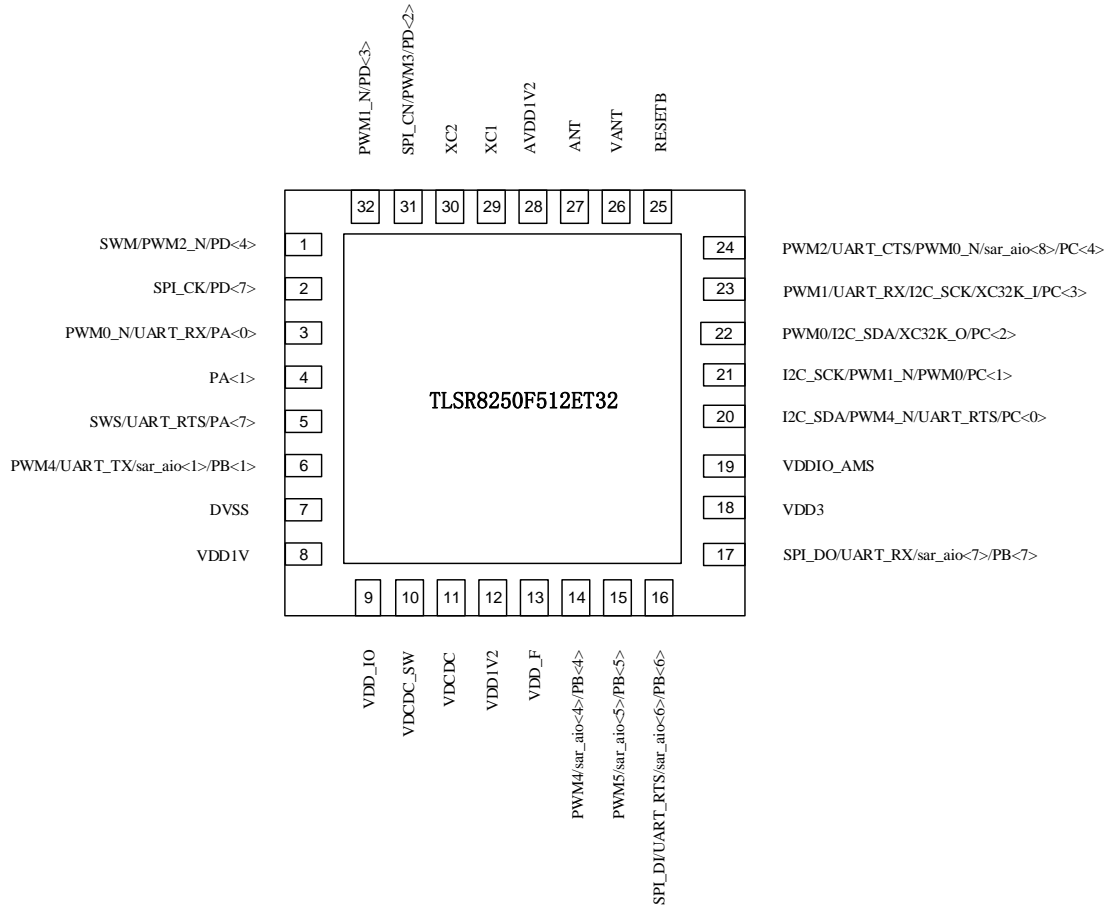

Figure 1- 4 Pin assignment for TLSR8250F512ET32

Functions of 32 pins for the TLSR8250F512ET32 are described in Table 1- 2.

Table 1- 2 Pin functions for TLSR8250F512ET32

No.	Pin Name	Type	Description
1	SWM/PWM2_N/PD<4>	Digital I/O	Single wire master / PWM2 inverting output / GPIO PD[4]
2	SPI_CK/PD<7>	Digital I/O	SPI clock (I2C_SCK) / GPIO PD[7]
3	PWM0_N/UART_RX/PA<0>	Digital I/O	PWM0 inverting output / UART_RX / GPIO PA[0]
4	PA<1>	Digital I/O	GPIO PA[1]
5	SWS/UART_RTS/PA<7>	Digital I/O	Single wire slave/ UART_RTS / GPIO PA[7]
6	PWM4/UART_TX/sar_aio<1>/PB<1>	Digital I/O	PWM4 output / UART_TX / SAR ADC input / GPIO PB[1]
7	DVSS	GND	Digital LDO ground
8	VDD1V	PWR	VDDDEC (Digital LDO 1.2V output)
9	VDD_IO	PWR	3.3V power supply for IO

No.	Pin Name	Type	Description
10	VDCDC_SW	Analog	Connect with VDCDC via external inductor
11	VDCDC	Analog	Connect with VDCDC_SW via external inductor
12	VDD1V2	PWR	Power domain of DCDC, connect GND via external capacitor
13	VDD_F	PWR	Power domain of flash, connect GND via external capacitor
14	PWM4/sar_aio<4>/PB<4>	Digital I/O	PWM4 output /SAR ADC input / GPIO PB[4]
15	PWM5/sar_aio<5>/PB<5>	Digital I/O	PWM5 output / SAR ADC input / GPIO PB[5]
16	SPI_DI/UART_RTS/sar_aio<6>/PB<6>	Digital I/O	SPI data input (I2C_SDA) / UART_RTS / SAR ADC input / GPIO PB[6]
17	SPI_DO/UART_RX/ sar_aio<7>/PB<7>	Digital I/O	SPI data output / UART_RX / SAR ADC input / GPIO PB[7]
18	VDD3	PWR	3.3V power supply
19	VDDIO_AMS	PWR	3.3V power domain (analog mix signal)
20	I2C_SDA/PWM4_N/UART_RTS/PC<0>	Digital I/O	I2C serial data / PWM4 inverting output / UART_RTS / GPIO PC[0]
21	I2C_SCK/PWM1_N/PWM0/PC<1>	Digital I/O	I2C serial clock / PWM1 inverting output / PWM0 output / GPIO PC[1]
22	PWM0/I2C_SDA/XC32K_O/PC<2>	Digital I/O	PWM0 output / I2C serial data / (optional) 32kHz crystal output / GPIO PC[2]
23	PWM1/UART_RX/I2C_SCK/XC32K_I/PC<3>	Digital I/O	PWM1 output / UART_RX / I2C serial clock / (optional) 32kHz crystal input / GPIO PC[3]
24	PWM2/UART_CTS/PWM0_N/sar_aio<8>/PC<4>	Digital I/O	PWM2 output / UART_CTS / PWM0 inverting output / SAR ADC input / GPIO PC[4]
25	RESETB	RESET	Power on reset, active low
26	VANT	PWR	Bias voltage to which the ANT pin is connected, connect to ANT using an external inductor
27	ANT	Analog	RF antenna, connect to VANT using external inductor
28	AVDD1V2	PWR	Supply for the internal RF Modules
29	XC1	Analog	Connect 24MHz crystal
30	XC2	Analog	Connect 24MHz crystal
31	SPI_CN/ PWM3/PD<2>	Digital I/O	SPI chip select (Active low) / PWM3 output / GPIO PD[2]
32	PWM1_N/ PD<3>	Digital I/O	PWM1 inverting output / GPIO PD[3]

### 1.6.2 Pin layout for TLSR8250F512ES16

Figure 1- 5 shows pin assignment for the TLSR8250F512ES16.

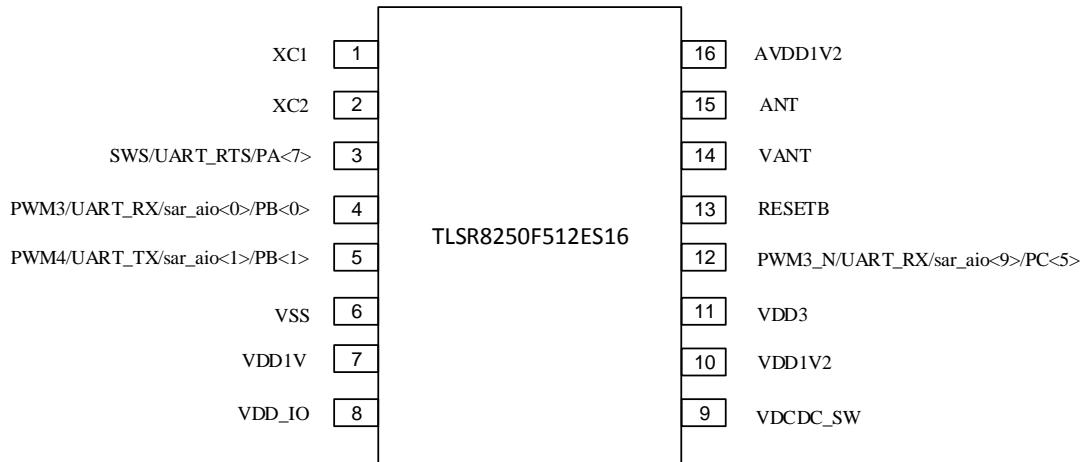

Figure 1- 5 Pin assignment for TLSR8250F512ES16

Functions of 16 pins for the TLSR8250F512ES16 are described in Table 1- 3.

Table 1- 3 Pin functions for TLSR8250F512ES16

No.	Pin Name	Type	Description
1	XC1	Analog	Connect 24MHz crystal
2	XC2	Analog	Connect 24MHz crystal
3	SWS/UART_RTS/PA<7>	Digital I/O	Single wire slave/ UART_RTS / GPIO PA[7]
4	PWM3/UART_RX/sar_aio<0>/ PB<0>	Digital I/O	PWM3 output / UART_RX / SAR ADC input / GPIO PB[0]
5	PWM4/UART_TX/sar_aio<1>/ PB<1>	Digital I/O	PWM4 output / UART_TX / SAR ADC input / GPIO PB[1]
6	VSS	GND	Ground for the whole chip
7	VDD1V	PWR	VDDDEC (Digital LDO 1.2V output)
8	VDD_IO	PWR	3.3V power supply for IO
9	VDCDC_SW	Analog	Connect with VDCDC via external inductor
10	VDD1V2	PWR	Power domain of DCDC, connect GND via external capacitor
11	VDD3	PWR	3.3V power supply for chip internal circuit
12	PWM3_N/UART_RX/sar_aio<9>/ PC<5>	Digital I/O	PWM3 inverting output / UART_RX / SAR ADC input / GPIO PC[5]
13	RESETB	RESET	Power on reset, active low
14	VANT	PWR	Bias voltage to which the ANT pin is connected, connect to ANT using an external inductor
15	ANT	Analog	RF antenna, connect to VANT using external inductor
16	AVDD1V2	PWR	Supply for the internal RF Modules



### 1.6.3 Notes

- 1) All digital IOs including PA<0> ~ PD<7> can be used as GPIOs and have configurable pull-up/pull-down resistor.
- 2) SPI:
  - ✧ PD<7>: SPI\_CK, PB<6>: SPI\_DI, PB<7>: SPI\_DO, PD<2>: SPI\_CN
- 3) I2C:
  - ✧ PC<0> ~ PC<3> can be used as I2C. PC<0>: I2C\_SDA, PC<1>: I2C\_SCK, PC<2>: I2C\_SDA, PC<3>: I2C\_SCK
  - ✧ I2C can also be multiplexed with SPI interface, i.e. I2C\_SDA/I2C\_SCK can be multiplexed with SPI\_DI (DI)/SPI\_CK (CK) respectively.
- 4) UART:
  - ✧ PA<0>: UART\_RX, PB<0>: UART\_RX, PB<1>: UART\_TX, PB<7>: UART\_RX, PC<3>: UART\_RX, PC<5>: UART\_RX
  - ✧ UART hardware flow control:
    - PA<7>: UART\_RTS, PB<6>: UART\_RTS, PC<0>: UART\_RTS, PC<4>: UART\_CTS
- 5) Single Wire debug interface:
  - ✧ PA<7>: SWS
  - ✧ PD<4>: SWM
- 6) ADC GPIO input:
  - ✧ TLSR8250F512ET32: PB<1>, PB<4>~PB<7>, PC<4>
  - ✧ TLSR8250F512ES16: PB<0>~PB<1>, PC<5>
- 7) For register configuration to select pin multiplexed function, please refer to section **7.1.1.2 Multiplexed functions**.
- 8) 32kHz crystal oscillator is only optional for the TLSR8250F512ET32 via PIN PC<2> and PC<3>.
- 9) For 24MHz crystal, the load capacitor range supported by design is 7.33pF~12.66pF. If the crystal needs load capacitor of 15pF, two external capacitors will be required.
- 10) Do not use PC<5> for dynamic applications. It's highly recommended to use the IO in DC applications, e.g. as control or detect line.
- 11) Pin drive strength:
  - ✧ PA<7> and PB<0:1> support drive strength up to 8mA (8mA when "DS"=1, 4mA when "DS"=0)
  - ✧ PB<4:7> support drive strength up to 16mA (16mA when "DS"=1, 12mA when "DS"=0)
  - ✧ Other GPIOs (PA<0:1>, PC<0:5>, PD<2:4>, PD<7>) support drive strength up to 4mA (4mA when "DS"=1, 2mA when "DS"=0).
  - ✧ "DS" configuration will take effect when the pin is used as output. Please refer to section **7.1.1 Basic configuration** for the corresponding "DS" register address and the default setting.

## 2 Memory and MCU

### 2.1 Memory

The TLSR8250F512 embeds 48kB SRAM (including up to 32kB SRAMs with retention in deep sleep, and one 16kB SRAM without retention) as data memory, and 512kB internal FLASH as program memory.

#### 2.1.1 SRAM/Register

SRAM/Register memory map is shown as follows:

16kB SRAM (without retention in deep)	0x84C000 0x84BFFF
16kB SRAM (with retention in deep)	0x848000 0x847FFF
8kB SRAM (with retention in deep)	0x844000 0x843FFF
8kB SRAM (with retention in deep)	0x842000 0x841FFF
Register	0x840000 0x83FFFF  0x800000

Figure 2- 1 Physical memory map

Register address: 0x800000 ~ 0x83FFFF.

Address for two independent 8kB SRAMs with retention in deep sleep: 0x840000 ~ 0x841FFF, 0x842000 ~ 0x843FFF.

Address for 16kB SRAM with retention in deep sleep: 0x844000 ~ 0x847FFF.

Address for 16kB SRAM without retention in deep sleep: 0x848000 ~ 0x84BFFF.

Both register and SRAM address can be accessed (read or write) via debugging interface (SWS/SWM, SPI/I2C interface).

Register  
(Base address: 0x800000)

RSVD	0x40000
Modem	0x01200
RSVD	0x01020
RSVD	0x01000
linklayer	0x00f00
RSVD	0x00d00
dma	0x00c00
DMA fifo	0x00b00
RSVD	0x00800
pwm	0x00780
System timer	0x00740
RSVD	0x00700
MCU	0x00600
gpio	0x00580
audio	0x00560
AES	0x00540
RSVD	0x00500
Baseband	0x00400
RSVD	0x00200
usb	0x00100
I2C address map	0x000e0
qdec	0x000d0
RSVD	0x000c0
RSVD	0x000b8
uart	0x000b4
swire	0x000b0
RSVD	0x000a0
uart	0x00090
RSVD	0x00080
System control	0x00040
RSVD	0x00010
RSVD	0x0000c
spi	0x00008
i2c	0x00000

Figure 2- 2 Register space

### 2.1.2 Flash

The internal Flash mainly supports page program, sector/block/chip erase operations, and deep power down operation. Please refer to the corresponding SDK for Flash memory operation details.

For chip identification and traceability, the Flash is preloaded with Unique ID (UID). User is not allowed to modify this preloaded UID, but can read the UID via corresponding API interface.

MCU uses the system frequency to load instructions, and adopts flash driver to access (read/write) flash with the speed of half of the system clock.

### 2.1.3 E-Fuse

The non-volatile E-Fuse section is preloaded with 4-byte decryption key and 4-byte chip UID, as shown below.

Table 2- 1 E-Fuse information

E-Fuse bit information	Decryption key	Chip UID				
		Coordinate X	Coordinate Y	Wafer No.	Lot No.	Internal information
	Bit0~31	Bit32~39	Bit40~47	Bit48~52	Bit53~55	Bit56~63

## 2.2 Firmware encryption

The TLSR8250F512 supports multiple firmware encryption methods to achieve the anti-cloning protection, including:

✧ UID-based authentication code generation method

During firmware burning (e.g. via specific burning jig), user can use customized key and AES encryption algorithm to encrypt the UID read from the chip flash, generate unique ciphertext and write the ciphertext into E-Fuse section.

During application, an encryption authentication procedure is added. User should use the same key and AES encryption algorithm to encrypt the UID read from the chip flash, and generate new ciphertext. Before running main application firmware, the new ciphertext will be compared with the ciphertext read from the E-Fuse section. Only when the authentication passes, i.e. the comparison result matches, the main firmware will be up and running, otherwise the chip will stop running the main firmware.

✧ Bootloader-based firmware encryption/decryption

The firmware can be encrypted using a customer-provided security key. The customer security key is written into a specific secure register, and becomes unreadable. Any attempt to read the key will only result in either all 1's or all 0's.

The encrypted firmware can be generated based on the plaintext firmware and the customer security key. The customer can burn the security key into the obscured memory area and also the encrypted firmware into Flash.

The firmware is readable by all, but appears as garbled binaries to 3<sup>rd</sup> party.

## 2.3 MCU

The TLSR8250F512 integrates a powerful 32-bit MCU developed by Telink. The digital core is based on 32-bit RISC, and the length of instructions is 16 bits; four hardware breakpoints are supported.

## 2.4 Working modes

The TLSR8250F512 supports six working modes, including Active, Idle, Suspend, Deep sleep with SRAM retention, deep sleep without SRAM retention, and Shutdown.

- ✧ The Power Management (PM) module is always active in all working modes.
- ✧ For modules such as MCU, RF transceiver (Radio), and SRAM, the state depends on working mode, as shown below.

Table 2- 2 Working modes

Mode	Active	Idle	Suspend	Deep sleep with SRAM retention	Deep sleep without SRAM retention	Shutdown
MCU	active	stall	stall	off	off	off
16k Normal SRAM (without retention in deep sleep)	on	on	on	off	off	off
Radio	available	available	off	off	off	off
Wakeup time to Active mode	---	0us	100us	Shorter than deep sleep without retention, almost same as Suspend	1ms	10ms
(16k+8k+8k) retention SRAMs (with retention in deep sleep)	full	full	full	full	off	off
Wakeup on RTC (32K Timer wakeup)	---	---	available	available	available	off
Wakeup on pin (IO wakeup)	---	---	available	available	available	off
Wakeup on interrupt	---	available	---	---	---	---
Wakeup on reset pin (RESETB)	---	available	available	available	available	on
Current	Please refer to section <b>12.3 DC characteristics.</b>					

**\*Notes:**

- 1) "active": MCU is at working state.
- 2) "stall": In Idle and Suspend mode, MCU does not work, while its clock is still running.
- 3) "available" for Modules: It's selectable to be at working state, or stall/be powered down if it does not need to work.
- 4) "available"/"on" for wakeup: Corresponding wakeup method is supported.

- 5) "off" for wakeup: Corresponding wakeup method is not supported.
- 6) "on"/"off"/"full" for SRAMs:
  - ✧ "on": The 16kB SRAM is powered on and works normally (can be accessed) in Active, Idle and Suspend mode.
  - ✧ "full": Full speed. In Active, Idle and Suspend mode, the two 8kB and one 16kB retention SRAMs are powered on and work normally (can be accessed); in Deep sleep with SRAM retention, the retention SRAMs are powered on, however, the contents of the retention SRAMs can be retained and cannot be accessed.
  - ✧ "off": The 16kB SRAM is powered down in two Deep sleep modes and Shutdown mode. The retention SRAMs are powered down in Deep sleep without SRAM retention and Shutdown mode.
- 7) Current:
  - ✧ In Deep sleep without SRAM retention, only the PM module is active, all digital and analog modules are powered down, thus the power consumption is largely decreased.
  - ✧ In Deep sleep with SRAM retention, the PM module is active, all analog and digital modules except for the retention SRAMs are powered down, thus the power consumption is a little higher than in Deep sleep without SRAM retention, but much lower than in Suspend.

Table 2- 3 Retention analog registers in deep sleep

Address	R/W	Description	Reset Value
0x35	R/W	buffer, watch dog reset clean	0x20
0x36	R/W	buffer, watch dog reset clean	0x00
0x37	R/W	buffer, watch dog reset clean	0x00
0x38	R/W	buffer, watch dog reset clean	0x00
0x39	R/W	buffer, watch dog reset clean	0xff
0x3a	R/W	buffer, power on reset clean	0x00
0x3b	R/W	buffer, power on reset clean	0x00
0x3c	R/W	buffer, power on reset clean	0x00

Analog registers (0x35 ~ 0x3c) as shown in Table 2- 3 are retained in deep sleep mode and can be used to store program state information across deep sleep cycles.

- ✧ Analog registers 0x3a~0x3c are non-volatile even when chip enters deep sleep or chip is reset by watchdog or software, i.e. the contents of these registers won't be changed by deep sleep or watchdog reset or chip software reset.
- ✧ Analog registers 0x35~0x39 are non-volatile in deep sleep, but will be cleared by watchdog reset or chip software reset.
- ✧ After POR (Power-On-Reset), all registers will be cleared to their default values, including these analog registers.

User can set flag in these analog registers correspondingly, so as to check the booting source

by reading the flag.

For chip software reset, please refer to section **2.5 Reset**.

## 2.5 Reset

The chip supports three types of reset methods, including POR (Power-On-Reset), watchdog reset and software reset.

- 1) POR: After power on, the whole chip will be reset, and all registers will be cleared to their default values.
- 2) Watchdog reset: A programmable watchdog is supported to monitor the system. If watchdog reset is triggered, registers except for the retention analog registers 0x3a~0x3c will be cleared.
- 3) Software reset: It is also feasible to carry out software reset for the whole chip or some modules.
  - ✧ Setting address 0x6f[5] as 1b'1 is to reset the whole chip. Similar to watchdog reset, the retention analog registers 0x3a~0x3c are non-volatile, while other registers including 0x35~0x39 will be cleared by chip software reset.
  - ✧ Addresses 0x60~0x62 serve to reset individual modules: if some bit is set to logic "1", the corresponding module is reset.

Table 2- 4 Register configuration for software reset

Address	Mnemonic	Type	Description	Reset Value
0x60	RST0	R/W	Reset control, 1 for reset, 0 for clear [0]: SPI [1]: I2C [2]: UART (rs232) [3]: RSVD (USB) [4]: PWM [5]: QDEC [6]: RSVD [7]: Swire	0x7c
0x61	RST1	R/W	[0] ZB [1] System Timer [2] DMA [3] ALGM [4] AES [5] ADC [6] ALG [7] RSVD	0xff
0x62	RST2	R/W	[0] AIF [1] RSVD (Audio) [2] DFIFO [3] RSVD [4] RISC	0xc7

Address	Mnemonic	Type	Description	Reset Value
			[5] MCIC [6] RISC1 (R) [7] MCIC1 (R)	
0x6f	PWDNEN	R/W	[0]: suspend enable (RW) [5]: rst all (act as watchdog reset) [6]: rsvd (mcu low power mode) (W) [7]: stall mcu trig If bit[0] set 1, then system will go to suspend. Or only stall mcu (W)	0x00

## 2.6 Power Management

The multiple-stage Power Management (PM) module is flexible to control power state of the whole chip or individual functional blocks such as MCU, RF Transceiver, and peripherals.

### 2.6.1 Power-On-Reset (POR) and Brown-out detect

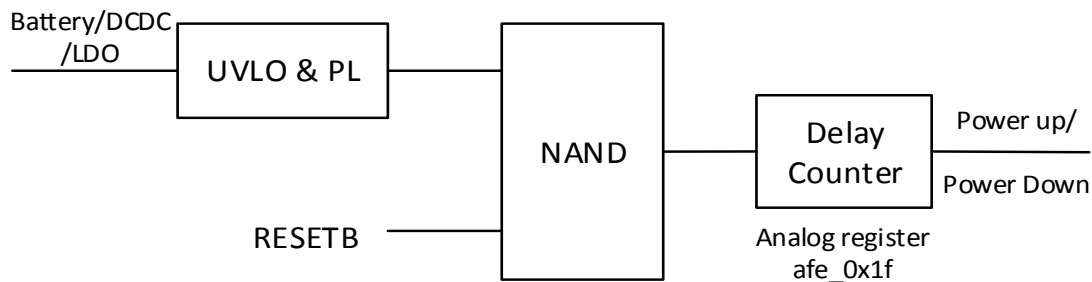

Figure 2- 3 Control logic for power up/down

The whole chip power up and down is controlled by the UVLO (Ultra-low Voltage Lockout) & PL (Power Logic) module and the external RESETB pin via the logic shown in the above diagram. UVLO takes the external power supply as input and releases the lock only when the power supply voltage is higher than a preset threshold. The RESETB pin has an internal pull-up resistor; an external Cap can be connected on the RESETB pin to control the POR delay.

After both UVLO and RESETB release, there is a further configurable delay before the system reset signal (“Sysrst”) is released. The delay is adjusted by analog register afe\_0x1f. Since the content of afe\_0x1f is reset to default only after power cycle, watchdog reset, or software reset, the delay change using afe\_0x1f is only applicable when the chip has not gone through these reset conditions. For example, after deep sleep wakeup, the setting in afe\_0x1f will take effect.

Table 2- 5 Analog register to control delay counters

Address	Name	Type	Description	Default
afe_0x1f	r_dly1	R/W	wait for DCDC ready (16kHz count)	0x40



### Initial Power up

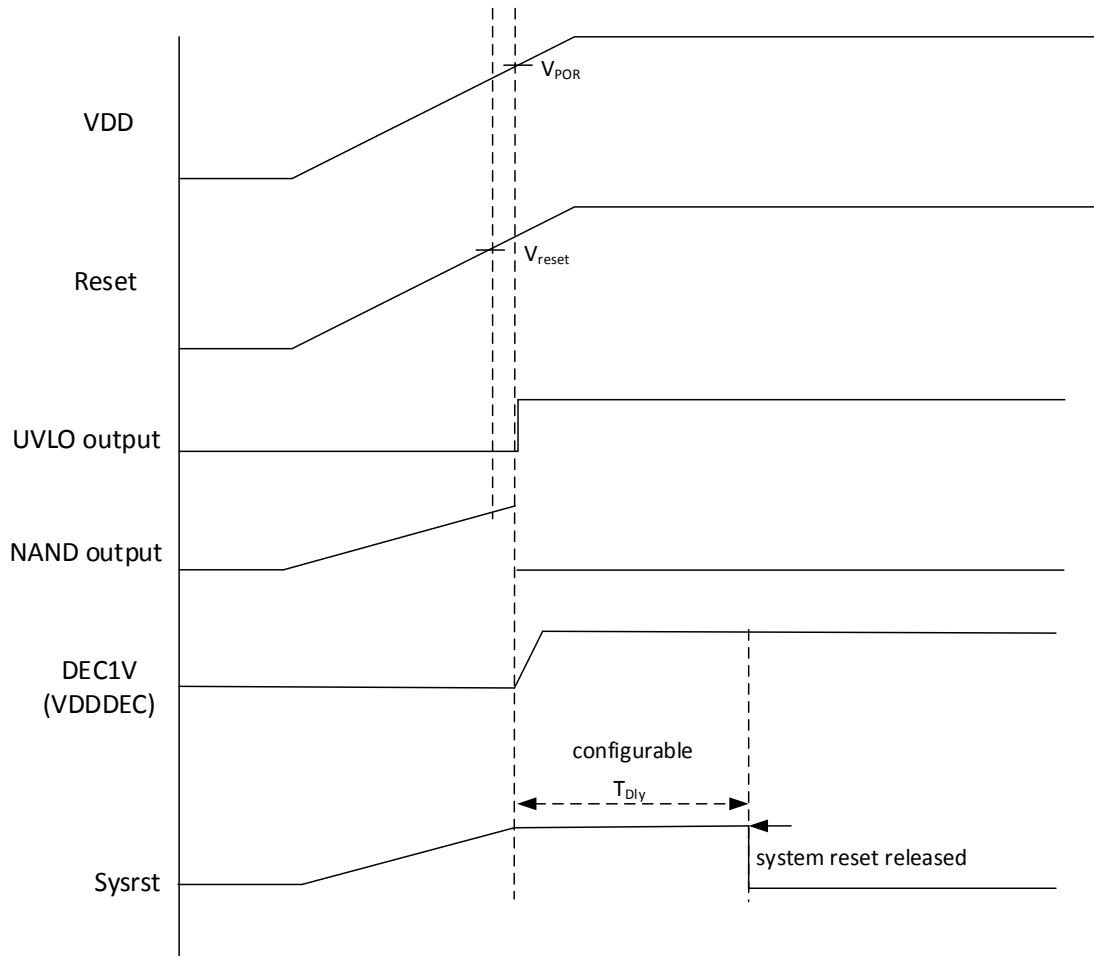

Figure 2-4 Initial Power-up sequence

**Power down**

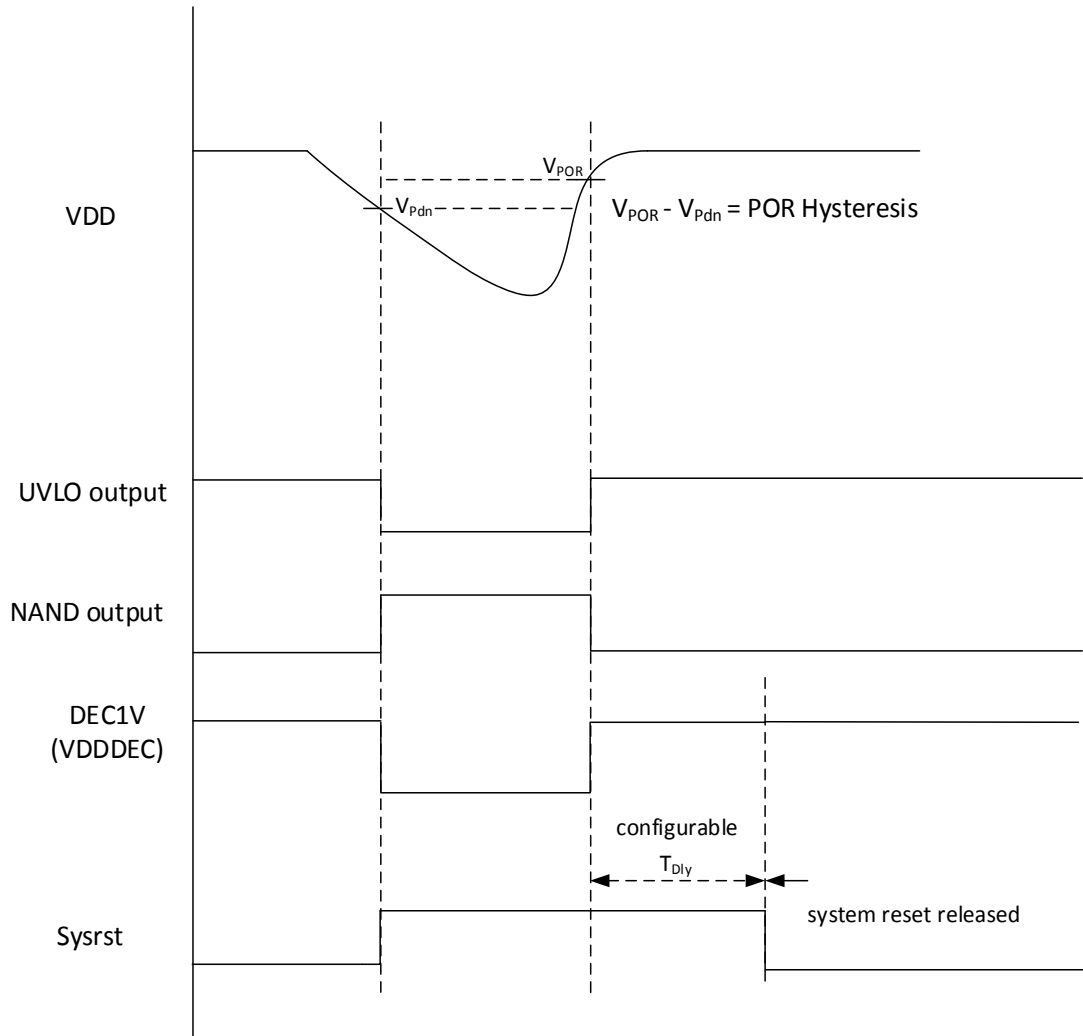

Figure 2- 5 Power-down sequence

Table 2- 6 Characteristics of Initial Power-up/ Power-down sequence

Symbol	Parameter	Min.	Typ.	Max.	Unit
$V_{POR}$	VDD voltage when $V_{UVLO}$ turns to high level		1.62		V
$V_{Pdn}$	VDD voltage when $V_{UVLO}$ turns to low level		1.55		V
$T_{Dly}$	Delay counter value	Configurable via analog register afe_0x1f			

### 2.6.2 Working mode switch

In Active mode, MCU is active, all SRAMs are accessible, and other modules are selectable whether to be at working state.

The chip can switch to Idle mode to stall the MCU. In this mode, all SRAMs are still accessible, modules such as RF transceiver are still selectable whether to be at working state. The chip can be triggered to Active mode by interrupt or RESETB pin, and the time to switch to Active mode is negligible.

To decrease power consumption to different levels, the chip can switch to power saving mode (Suspend, Deep sleep with SRAM retention, Deep sleep without SRAM retention, Shutdown) correspondingly. (Please refer to Table 2- 2.)

- ✧ In Suspend mode, MCU stalls, all SRAMs are still accessible, the PM module is active, and modules such as RF transceiver are powered down. The chip can be triggered to Active mode by 32k Timer, IO pin or RESETB pin. It takes 100us or so to switch from Suspend mode to Active mode.
- ✧ In Deep sleep with SRAM retention, the PM module is active, analog and digital modules except for the two 8kB and one 16kB retention SRAMs are powered down, while the retention SRAMs can be retained and not accessible. The chip can be triggered to Active mode by 32k Timer, IO pin or RESETB pin. The time to switch to Active mode is shorter than Deep sleep without SRAM retention and close to Suspend.
- ✧ In Deep sleep without SRAM retention, only the PM module is active, while analog and digital modules including the retention SRAMs are powered down. The chip can be triggered to Active mode by 32k Timer, IO pin or RESETB pin. The time to switch to Active mode is 1ms or so.
- ✧ In Shutdown mode, all digital and analog modules are powered down, and only the PM module is active. The chip can be triggered to Active mode by RESETB pin only. The time to switch to Active mode is 10ms or so.

User can directly invoke corresponding library function to switch working mode of the chip.

If certain module doesn't need to work, user can power down this module in order to save power.

Table 2- 7 3.3V analog registers for module power up/down control

Address	Local name	Default	Description
afe_0x05<0>	32K_rc_pd	0	Power down 32kHz RC oscillator 1: Power down, 0: Power up
afe_0x05<1>	32k_xtal_pd	1	Power down 32kHz crystal 1: power down, 0: power up
afe_0x05<2>	24M_rc_pd	0	Power down of 24MHz RC oscillator 1: Power down, 0: Power up
afe_0x05<3>	xtal_LDO_pd	0	Power down of 24MHz crystal oscillator 1: Power down, 0: Power up

Address	Local name	Default	Description
afe_0x05<4>	pd_pl_all_3v	0	Power down of power logic, 4.2V VBUS_LDO and DCDC 1: Power down, 0: Power up
afe_0x05<5>	pd_pl_dc dc_3v	0	Power down of DCDC 1: Power down, 0: Power up
afe_0x05<6>	pd_pl_vbus_ldo_3v	0	Power down of VBUS_LDO 1: Power down, 0: Power up
afe_0x05<7>	ana_ldo_pd_3V	0	Power down baseband pll LDO 1: Power down, 0: Power up
afe_0x06	rsvd		
afe_0x07<0>	spd_ldo_pd	1	Power down of spd ldo 1: Power down, 0: power up
afe_0x07<1>	dig_ldo_pd	0	Power down of main digital ldo 1: Power down, 0: power up
afe_0x07<2>	dig_ret_pd	1	Power down of retention ldo 1: Power down, 0: power up
afe_0x07<3>	pd_lc_comp_3v	1	RSVD (Power down of low current comparator: 1: Power down, 0: Power up)
afe_0x07<4>	pd_temp_sensor_3v	1	Power down of temperature sensor: 1: Power down, 0: Power up

### 2.6.3 LDO and DCDC

The chip embedded DCDC can generate 1.8V output voltage and supply power for the internal flash; the DCDC can also generate 1.4V output voltage.

The embedded LDO regulator takes the 1.4V voltage output from the DCDC, and generates 1.2V regulated voltage to supply power for 1.2V digital core and analog modules in Active/Idle/Suspend mode.

### 2.6.4 VBAT and VANT power-supply mode

The chip provides two power-supply modes including VBAT mode and VANT mode.

- ✧ In VBAT mode, the chip is directly supplied with power by its battery voltage. The maximum output power is related to power supply voltage, for example, the maximum power is 10dBm or so at 3.3V power supply.
- ✧ In VANT mode, the chip is supplied with 1.2V voltage by the embedded DCDC and LDO. In this mode, output power won't change with AVDD basically, and the maximum power is 5dBm or so. Corresponding to the VBAT mode, the VANT mode is more power-saving at the same Tx power.

## 2.7 Wakeup sources

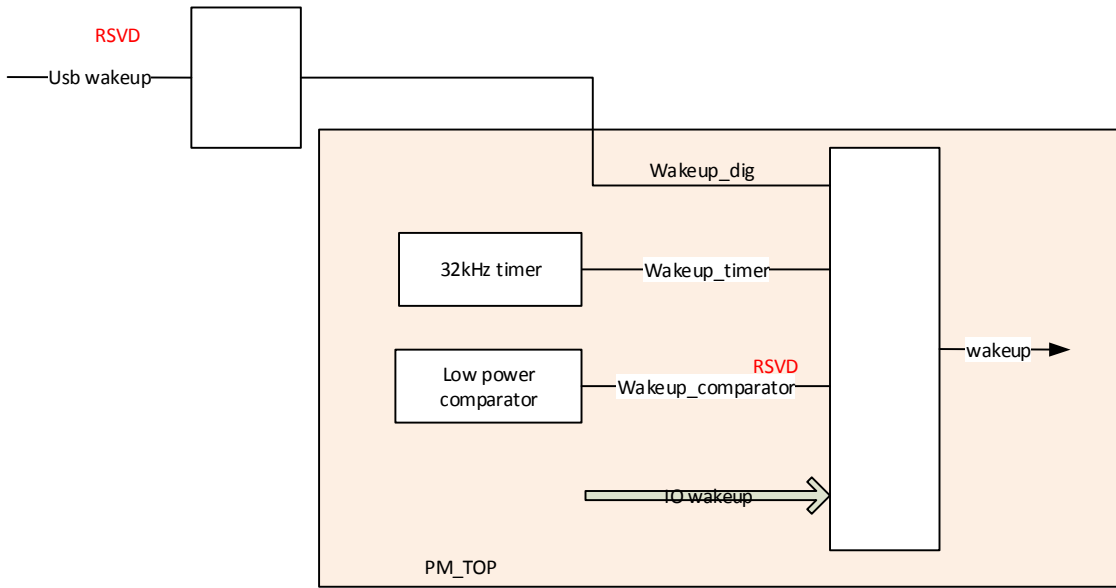

Figure 2- 6 Wakeup sources

### 2.7.1 Wakeup source – 32kHz timer

This wakeup source is able to wake up the system from suspend mode or two deep sleep modes.

To enable the wakeup source from 32kHz timer, analog register `afe_0x26[6]` should be set as 1b'1.

### 2.7.2 Wakeup source – IO

This wakeup source is able to wake up the system from suspend mode or two deep sleep modes. And IO wakeup supports high level or low level wakeup which is configurable via polarity control registers.

Analog register `afe_0x26[4]` should be set as 1b'1 to enable IO wakeup source.

Enabling control analog registers: PA[7:0] enabling control register is `afe_0x27[7:0]`, PB[7:0] enabling control register is `afe_0x28[7:0]`, PC[7:0] enabling control register is `afe_0x29[7:0]`, and PD[7:0] enabling control register is `afe_0x2a[7:0]`. Total wakeup pin can be up to 32.

Polarity control registers: PA[7:0] polarity control register is `afe_0x21[7:0]`, PB[7:0] polarity control register is `afe_0x22[7:0]`, PC[7:0] polarity control register is `afe_0x23[7:0]`, and PD[7:0] polarity control register is `afe_0x24[7:0]`.

The corresponding driver is available so that user can directly invoke it to use IO wakeup source.

Analog register `0x44[3:0]` indicates the wakeup source which triggers system wakeup. After wakeup, the corresponding wakeup status will be set as 1b'1 automatically, and it's needed to write 1 to manually clean the status.

**2.7.3 Register table**

Table 2- 8 Analog registers for Wakeup

Address	Name	Type	Description	Default
afe_0x21	PA_POL	R/W	Polarity control registers for IO wakeup	0x00
afe_0x22	PB_POL	R/W		0x00
afe_0x23	PC_POL	R/W		0x00
afe_0x24	PD_POL	R/W		0x00
afe_0x25	rsvd	R		
afe_0x26	wkup_en	R/W	[7] RSVD (low power comparator wakeup enable)	0x00
			[6] 32kHz timer wakeup enable	
			[5] RSVD (digital core wakeup enable )	
			[4] IO (pad) wake up enable	
			[3] Enable/Mask filter for IO (Pad) wakeup 1: Select 16us filter to filter out jitter on IO PAD input. 0: IO Pad combinational logic output (disable filter)	
afe_0x27	PA wake up enable	R/W	Enabling control registers for IO wakeup	0x00
afe_0x28	PB wake up enable	R/W		0x00
afe_0x29	PC wake up enable	R/W		0x00
afe_0x2a	PD wake up enable	R/W		0x00
afe_0x44	status	R	[7] dcdc_rdy	
			[6] wd_status	
			[5] cal_done_24m	
			[4] cal_done_32k	
			[3] IO (pad) wakeup status	
			[2] RSVD (digital core wakeup status)	
			[1] 32k timer wakeup status	
			[0] RSVD (low power comparator wakeup status)	

Table 2- 9 Digital register for Wakeup

Address	Mnemonic	Type	Description	Reset Value
0x6e	WAKEUPEN	R/W	Wakeup enable [0]: enable wakeup from I2C host [1]: enable wakeup from SPI host [2]: enable wakeup from USB [3]: enable wakeup from gpio [4]: enable wakeup from I2C synchronous interface System resume control [5]: enable GPIO remote wakeup [6]: if set to 1, system will issue USB resume signal on USB bus [7] sleep wakeup reset system enable	0x1f

### 3 BLE/2.4GHz RF Transceiver

#### 3.1 Block diagram

The TLSR8250F512 integrates an advanced BLE/2.4GHz RF transceiver. The RF transceiver works in the worldwide 2.4GHz ISM (Industrial Scientific Medical) band.

The transceiver consists of a fully integrated RF synthesizer, a Power Amplifier (PA), a Low Noise Amplifier (LNA), a TX filter, a RX filter, a TX DAC, an ADC, a modulator and a demodulator. The transceiver can be configured to work in standard-compliant 1Mbps BLE mode.

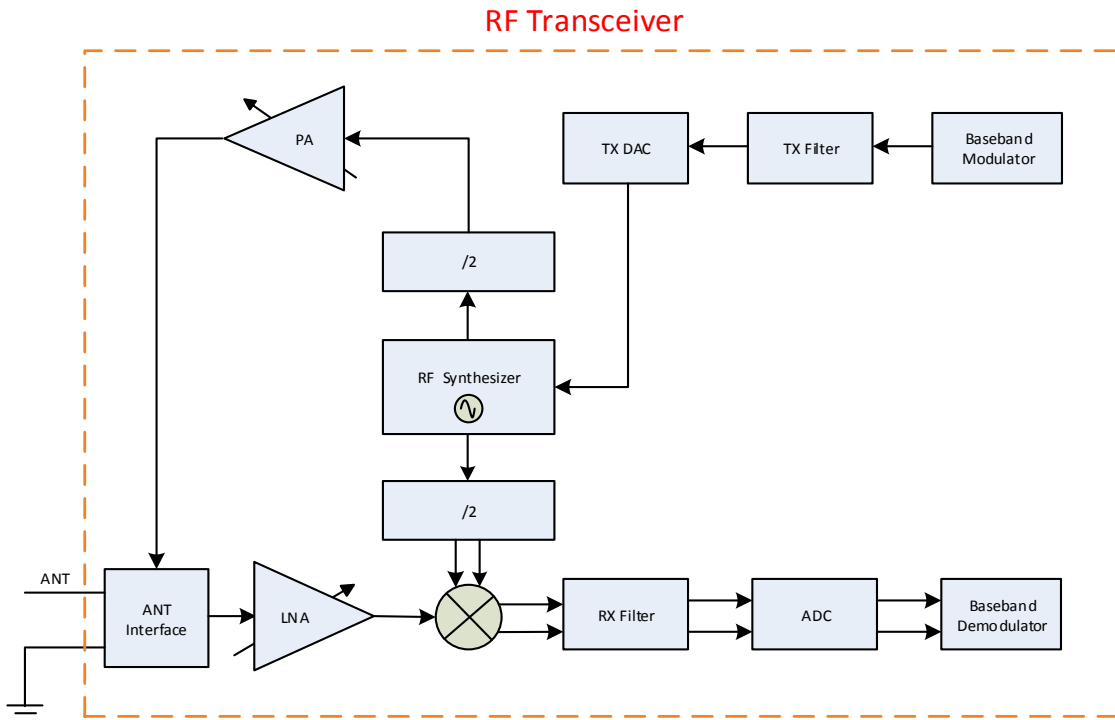

Figure 3- 1 Block diagram of RF transceiver

The internal PA can deliver a maximum 10dBm output power, avoiding the need for an external RF PA.

### 3.2 Air interface data rate and RF channel frequency

Air interface data rate, the modulated signaling rate for RF transceiver when transmitting and receiving data, can be configured as 1Mbps.

For the TLSR8250F512, RF transceiver can operate with frequency ranging from 2.400GHz to 2.4835GHz. The RF channel frequency setting determines the center of the channel.

### 3.3 Baseband

The baseband is disabled by default. The corresponding API is available for user to power on/down the baseband and enable/disable clock, so that the baseband can be turned on/off flexibly.

The baseband contains dedicated hardware logic to perform fast AGC control, access code correlation, CRC checking, data whitening, encryption/decryption and frequency hopping logic.

The baseband supports all mandatory features required by Bluetooth 5 specification.

#### 3.3.1 Packet format

Packet format in standard 1Mbps BLE mode is shown as Table 3- 1:

Table 3- 1 Packet Format in standard 1Mbps BLE mode

LSB		MSB	
Preamble (1 octet)	Access Address (4 octets)	PDU (2 ~ 257 octets)	CRC (3 octets)

Packet length 80bit ~ 2120bit (80~2120us @ 1Mbps).

#### 3.3.2 RSSI and frequency offset

The TLSR8250F512 provides accurate RSSI (Receiver Signal Strength Indicator) and frequency offset indication.

- ✧ RSSI can be read from the 1byte at the tail of each received data packet.
- ✧ If no data packet is received (e.g. to perform channel energy measurement when no desired signal is present), real-time RSSI can also be read from specific registers which will be updated automatically.
- ✧ RSSI monitoring resolution can reach +/-1dB.
- ✧ Frequency offset can be read from the 2bytes at the tail of the data packet. Valid bits of actual frequency offset may be less than 16bits, and different valid bits correspond to different tolerance range.

Telink supplies corresponding drivers for user to read RSSI and frequency offset as needed.



## 4 Clock

### 4.1 Clock sources

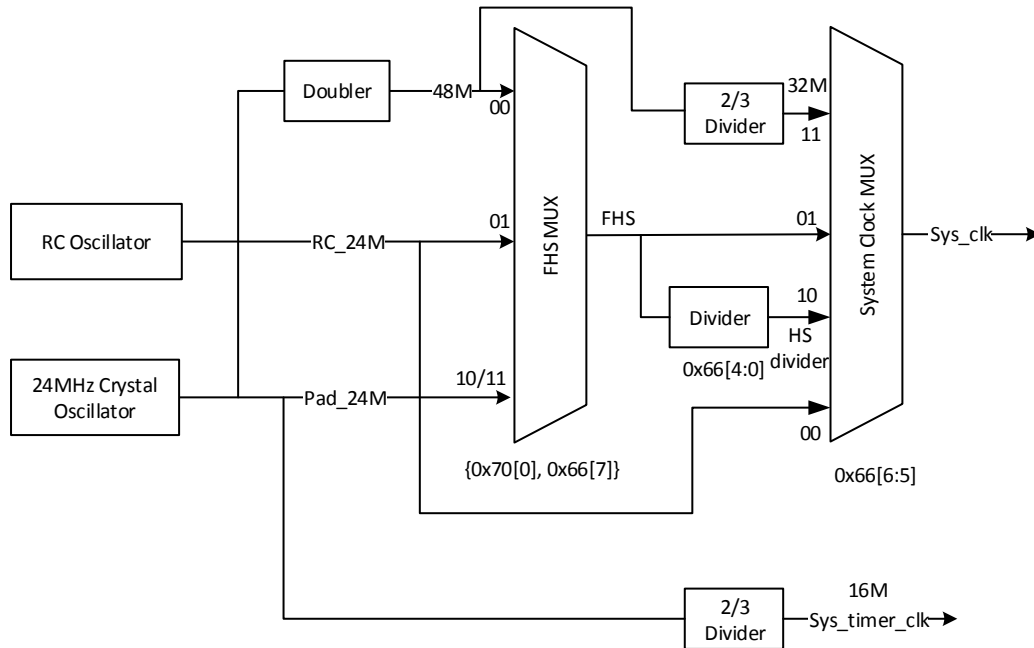

Figure 4- 1 Block diagram of clock

The TLSR8250F512 embeds a 24MHz RC oscillator which can be used as clock source for system, as well as a 32kHz RC oscillator to provide clock source for sleep state.

External 24MHz crystal is available via pin XC1 and XC2, which can provide a Pad\_24MHz clock source for system and System Timer, and generate a 48M clock via a frequency doubler.

For the TLSR8250F512ET32, external 32kHz crystal is available via pin PC<2:3>, which can provide a 32kHz clock source.

### 4.2 System clock

There are four selectable clock sources for MCU system clock: **RC\_24M** derived from 24MHz RC oscillator, High speed clock “**FHS**”, **HS divider clock** (derived from “FHS” via a frequency divider), and **32MHz clock** derived from 48MHz clock via a 2/3 frequency divider (The 48M clock is derived from 24M crystal oscillator via a frequency doubler).

The high speed clock (FHS) is selectable via address {0x70[0], 0x66[7]} from the following sources: **48MHz** clock (derived from 24M crystal oscillator via a frequency doubler), **RC\_24M** (derived from 24MHz RC oscillator), and **Pad\_24M** (derived from 24M crystal oscillator).

The digital register CLKSEL (address 0x66) serves to set system clock: System clock source is selectable via bit[6:5].

- ✧ If address 0x66[6:5] is set to 2b'10 to select the HS divider clock, system clock frequency is adjustable via address 0x66[4:0]. The formula is shown as below:

$$F_{\text{System clock}} = F_{\text{FHS}} / (\text{system clock divider value in address } 0x66[4:0]).$$

Note that address 0x66[4:0] should not be set as 0 or 1.

### 4.3 Module clock

Registers CLKEN0~CLKEN2 (address 0x63~0x65) are used to enable or disable clock for various modules. By disable the clocks of unused modules, current consumption could be reduced.

#### 4.3.1 System Timer clock

System Timer clock is derived from 24M crystal oscillator via a 2/3 frequency divider. The clock frequency is fixed as 16MHz.

### 4.4 Register table

Table 4- 1 Register table related to clock

Address	Mnemonic	R/W	Description	Default
0x63	CLKEN0	R/W	Clock enable control: 1 for enable; 0 for disable [0]: SPI [1]: I2C [2]: UART (rs232) [3]: RSVD (USB) [4]: PWM [5]: QDEC [6]: RSVD [7]: Swire	0x83
0x64	CLKEN1	R/W	[0]ZB [1]System Timer [2]DMA [3]ALGM [4]AES [5:7]RSVD	0x00
0x65	CLKEN2	R/W	[0]AIF [1]RSVD (Audio) [2]DFIFO [3]RSVD [4]MC [5]MCIC [6:7]RSVD	0x30
0x66	CLKSEL	R/W	System clock select [4:0]: system clock divider (must exceed 1). If 0x66[6:5] is set as 2'b'10, $F_{Sysclk} = F_{FHS} / (CLKSEL[4:0])$ . FHS: refer to 0x70 CLKSEH. [6:5]: select system clock source 2'b00: RC_24M from RC oscillator 2'b01: FHS 2'b10: HS divider (see 0x66[4:0]) 2'b11: 32M clock (48M * 2/3 divider) [7] FHS select (see 0x70[0])	0x06

Address	Mnemonic	R/W	Description	Default
0x67	I2S_STEP	R/W	RSVD	0x00
0x68	I2S_MOD	R/W	RSVD	0x02
0x6c	DMIC_STEP	R/W	RSVD	0x01
0x6d	DMIC_MOD	R/W	RSVD	0x02
0x70	CLKSEH	R/W	{0x70[0], 0x66[7]} FHS select 2'b00: 48M clock doubled from 24M crystal 2'b01: RC_24M from RC oscillator 2'b1x: Pad_24M from 24M crystal oscillator	0x00
0x73	SEL	R/W	[0]: clk32k select 0: select RC_32k from RC oscillator 1: select Pad_32k from 32K crystal oscillator [1]: RSVD (DMIC clock select 1: select 32k (see 0x73[0] to select 32K source) 0: select DMIC clk div (see 0x6c~0x6d))	0x04

## 5 Timers

### 5.1 Timer0~Timer2

The TLSR8250F512 supports three timers: Timer0~ Timer2. The three timers all support four modes: Mode 0 (System Clock Mode), Mode 1 (GPIO Trigger Mode), Mode 2 (GPIO Pulse Width Mode) and Mode 3 (Tick Mode), which are selectable via the register TMR\_CTRL0 (address 0x620) ~ TMR\_CTRL1 (address 0x621).

Timer 2 can also be configured as “watchdog” to monitor firmware running.

#### 5.1.1 Register table

Table 5- 1 Register configuration for Timer0~Timer2

Address	Mnemonic	Type	Description	Reset Value
0x72	Wd_status	R/W	[0] watch dog status, write 1 to clear.	
0x620	TMR_CTRL0	RW	[0]Timer0 enable [2:1] Timer0 mode. 0: using sclk, 1: using gpio, 2: count width of gpi, 3: tick [3]Timer1 enable [5:4] Timer1 mode. [6]Timer2 enable [7]Bit of timer2 mode	00
0x621	TMR_CTRL1	RW	[0]Bit of timer2 mode [7:1]Low bits of watch dog capture	00
0x622	TMR_CTRL2	RW	[6:0]High bits of watch dog capture. It is compared with [31:18] of timer2 ticker [7]watch dog capture	00
0x623	TMR_STATUS	RW	[0] timer0 status, write 1 to clear [1] timer1 status, write 1 to clear [2] timer2 status, write 1 to clear	
0x624	TMR_CAPT0_0	RW	Byte 0 of timer0 capture	00
0x625	TMR_CAPT0_1	RW	Byte 1 of timer0 capture	00
0x626	TMR_CAPT0_2	RW	Byte 2 of timer0 capture	00
0x627	TMR_CAPT0_3	RW	Byte 3 of timer0 capture	00
0x628	TMR_CAPT1_0	RW	Byte 0 of timer1 capture	00
0x629	TMR_CAPT1_1	RW	Byte 1 of timer1 capture	00
0x62a	TMR_CAPT1_2	RW	Byte 2 of timer1 capture	00
0x62b	TMR_CAPT1_3	RW	Byte 3 of timer1 capture	00
0x62c	TMR_CAPT2_0	RW	Byte 0 of timer2 capture	00
0x62d	TMR_CAPT2_1	RW	Byte 1 of timer2 capture	00
0x62e	TMR_CAPT2_2	RW	Byte 2 of timer2 capture	00
0x62f	TMR_CAPT2_3	RW	Byte 3 of timer2 capture	00
0x630	TMR_TICK0_0	RW	Byte 0 of timer0 ticker	
0x631	TMR_TICK0_1	RW	Byte 1 of timer0 ticker	
0x632	TMR_TICK0_2	RW	Byte 2 of timer0 ticker	
0x633	TMR_TICK0_3	RW	Byte 3 of timer0 ticker	

Address	Mnemonic	Type	Description	Reset Value
0x634	TMR_TICK1_0	RW	Byte 0 of timer1 ticker	
0x635	TMR_TICK1_1	RW	Byte 1 of timer1 ticker	
0x636	TMR_TICK1_2	RW	Byte 2 of timer1 ticker	
0x637	TMR_TICK1_3	RW	Byte 3 of timer1 ticker	
0x638	TMR_TICK2_0	RW	Byte 0 of timer2 ticker	
0x639	TMR_TICK2_1	RW	Byte 1 of timer2 ticker	
0x63a	TMR_TICK2_2	RW	Byte 2 of timer2 ticker	
0x63b	TMR_TICK2_3	RW	Byte 3 of timer2 ticker	

### 5.1.2 Mode0 (System Clock Mode)

In Mode 0, system clock is employed as clock source.

After Timer is enabled, Timer Tick (i.e. counting value) is increased by 1 on each positive edge of system clock from preset initial Tick value. Generally the initial Tick value is set to 0.

Once current Timer Tick value matches the preset Timer Capture (i.e. timing value), an interrupt is generated, Timer stops counting and Timer status is updated.

Steps of setting Timer0 for Mode 0 is taken as an example.

#### 1<sup>st</sup>: Set initial Tick value of Timer0

Set Initial value of Tick via registers TMR\_TICK0\_0~TMR\_TICK0\_3 (address 0x630~0x633). Address 0x630 is lowest byte and 0x633 is highest byte. It's recommended to clear initial Timer Tick value to 0.

#### 2<sup>nd</sup>: Set Capture value of Timer0

Set registers TMR\_CAPT0\_0~TMR\_CAPT0\_3 (address 0x624~0x627). Address 0x624 is lowest byte and 0x627 is highest byte.

#### 3<sup>rd</sup>: Set Timer0 to Mode 0 and enable Timer0

Set register TMR\_CTRL0 (address 0x620) [2:1] to 2b'00 to select Mode 0; Meanwhile set address 0x620[0] to 1b'1 to enable Timer0. Timer0 starts counting upward, and Tick value is increased by 1 on each positive edge of system clock until it reaches Timer0 Capture value.

### 5.1.3 Mode1 (GPIO Trigger Mode)

In Mode 1, GPIO is employed as clock source. The "m0"/"m1"/"m2" register specifies the GPIO which generates counting signal for Timer0/Timer1/Timer2.

After Timer is enabled, Timer Tick (i.e. counting value) is increased by 1 on each positive/negative (configurable) edge of GPIO from preset initial Tick value. Generally the initial Tick value is set to 0. The "Polarity" register specifies the GPIO edge when Timer Tick counting increases.

**Note:** Refer to **Section 7.1.2** for corresponding "m0", "m1", "m2" and "Polarity" register address.

Once current Timer Tick value matches the preset Timer Capture (i.e. timing value), an interrupt is generated and timer stops counting.

Steps of setting Timer1 for Mode 1 is taken as an example.

**1<sup>st</sup>: Set initial Tick value of Timer1**

Set Initial value of Tick via registers TMR\_TICK1\_0~TMR\_TICK1\_3 (address 0x634~0x637). Address 0x634 is lowest byte and 0x637 is highest byte. It's recommended to clear initial Timer Tick value to 0.

**2<sup>nd</sup>: Set Capture value of Timer1**

Set registers TMR\_CAPT1\_0~TMR\_CAPT1\_3 (address 0x628~0x62b). Address 0x628 is lowest byte and 0x62b is highest byte.

**3<sup>rd</sup>: Select GPIO source and edge for Timer1**

Select certain GPIO to be the clock source via setting "m1" register.

Select positive edge or negative edge of GPIO input to trigger Timer1 Tick increment via setting "Polarity" register.

**4<sup>th</sup>: Set Timer1 to Mode 1 and enable Timer1**

Set address 0x620[5:4] to 2b'01 to select Mode 1; Meanwhile set address 0x620[3] to 1b'1 to enable Timer1. Timer1 starts counting upward, and Timer1 Tick value is increased by 1 on each positive/negative (specified during the 3<sup>rd</sup> step) edge of GPIO until it reaches Timer1 Capture value.

**5.1.4 Mode2 (GPIO Pulse Width Mode)**

In Mode 2, system clock is employed as the unit to measure the width of GPIO pulse. The "m0"/"m1"/"m2" register specifies the GPIO which generates control signal for Timer0/Timer1/Timer2.

After Timer is enabled, Timer Tick is triggered by a positive/negative (configurable) edge of GPIO pulse. Then Timer Tick (i.e. counting value) is increased by 1 on each positive edge of system clock from preset initial Tick value. Generally the initial Tick value is set to 0. The "Polarity" register specifies the GPIO edge when Timer Tick starts counting.

**Note:** Refer to **Section 7.1.2** for corresponding "m0", "m1", "m2" and "Polarity" register address.

While a negative/positive edge of GPIO pulse is detected, an interrupt is generated and timer stops counting. The GPIO pulse width could be calculated in terms of tick count and period of system clock.

Steps of setting Timer2 for Mode 2 is taken as an example.

**1<sup>st</sup>: Set initial Timer2 Tick value**

Set Initial value of Tick via registers TMR\_TICK2\_0~TMR\_TICK2\_3 (address 0x638~0x63b). Address 0x638 is lowest byte and 0x63b is highest byte. It's recommended to clear initial Timer Tick value to 0.

**2<sup>nd</sup>: Select GPIO source and edge for Timer2**

Select certain GPIO to be the clock source via setting "m2" register.

Select positive edge or negative edge of GPIO input to trigger Timer2 counting start via setting "Polarity" register.

**3<sup>rd</sup>: Set Timer2 to Mode 2 and enable Timer2**

Set address 0x620[7:6] to 2b'01 and address 0x621 [0] to 1b'1.

Timer2 Tick is triggered by a positive/negative (specified during the 2<sup>nd</sup> step) edge of GPIO pulse. Timer2 starts counting upward and Timer2 Tick value is increased by 1 on each positive edge of system clock.

While a negative/positive edge of GPIO pulse is detected, an interrupt is generated and Timer2 tick stops.

**4<sup>th</sup>: Read current Timer2 Tick value to calculate GPIO pulse width**

Read current Timer2 Tick value from address 0x638~0x63b.

Then GPIO pulse width is calculated as follows:

GPIO pulse width = System clock period \* (current Timer2 Tick – initial Timer2 Tick)

For initial Timer2 Tick value is set to the recommended value of 0, then:

GPIO pulse width = System clock period \* current Timer2 Tick.

### 5.1.5 Mode3 (Tick Mode)

In Mode 3, system clock is employed.

After Timer is enabled, Timer Tick starts counting upward, and Timer Tick value is increased by 1 on each positive edge of system clock.

This mode could be used as time indicator. There will be no interrupt generated. Timer Tick keeps rolling from 0 to 0xffffffff. When Timer tick overflows, it returns to 0 and starts counting upward again.

Steps of setting Timer0 for Mode 3 is taken as an example.

**1<sup>st</sup>: Set initial Tick value of Timer0**

Set Initial value of Tick via address 0x630~0x633. Address 0x630 is lowest byte and address 0x633 is highest byte. It's recommended to clear initial Timer Tick value to 0.

**2<sup>nd</sup>: Set Timer0 to Mode 3 and enable Timer0**

Set address 0x620[2:1] to 2b'11 to select Mode 3, meanwhile set address 0x620[0] to 1b'1 to enable Timer0. Timer0 Tick starts to roll.

**3<sup>rd</sup>: Read current Timer0 Tick value**

Current Timer0 Tick value can be read from address 0x630~0x633.

### 5.1.6 Watchdog

Programmable watchdog could reset chip from unexpected hang up or malfunction.

Only Timer2 supports Watchdog.

Timer2 Tick has 32bits. Watchdog Capture has only 14bits, which consists of TMR\_CTRL2 (address 0x622) [6:0] as higher bits and TMR\_CTRL1 (address 0x621) [7:1] as lower bits. Chip will be reset when the Timer2 Tick[31:18] matches Watch dog capture.

**1<sup>st</sup>: Clear Timer2 Tick value**

Clear registers TMR\_TICK2\_0 ~TMR\_TICK2\_3 (address 0x638~0x63b). Address 0x638 is lowest byte and 0x63b is highest byte.

### 2<sup>nd</sup>: Enable Timer2

Set register TMR\_CTRL0 (address 0x620) [6] to 1b'1 to enable Timer2.

### 3<sup>rd</sup>: Set 14-bit Watchdog Capture value and enable Watchdog

Set address 0x622[6:0] as higher bits of watchdog capture and 0x621[7:1] as lower bits. Meanwhile set address 0x622[7] to 1b'1 to enable Watchdog.

Then Timer2 Tick starts counting upwards from 0.

If bits[31:18] of Timer2 Tick value read from address 0x638~0x63b reaches watchdog capture, the chip will be reset, and the status bit in address 0x72[0] will be set as 1b'1 automatically. User can read the watchdog status bit after chip reset to check if the reset source is watchdog, and needs to write 1b'1 to this bit to manually clear the flag.

## 5.2 32K LTIMER

The TLSR8250F512 also supports a low frequency (32kHz) LTIMER in suspend mode or deep sleep mode. This timer can be used as one kind of wakeup source.

## 5.3 System Timer

The TLSR8250F512 also supports a System Timer. As introduced in section 4.3.1 **System Timer clock**, the clock frequency for System Timer is fixed as 16MHz irrespective of system clock.

In suspend mode, both System Timer and Timer0~Timer2 stop counting, and 32K Timer starts counting. When the chip restores to active mode, Timer0~Timer2 will continue counting from the number when they stops; In contrast, System Timer will continue counting from an adjusted number which is a sum of the number when it stops and an offset calculated from the counting value of 32K Timer during suspend mode.

Table 5- 2 Register table for System Timer

Address	Mnemonic	R/W	Function	Default Value
0x740	SYS_TIMER0	R/W	[7:3]	0x00
0x741	SYS_TIMER1	R/W	[7:0]	0x00
0x742	SYS_TIMER2	R/W	[7:0]	0x00
0x743	SYS_TIMER3	R/W	[7:0] System timer counter, write to set initial value. This is the sys timer counter	0x00
0x74c	SYS_TIMER_CTRL0	R/W	[7]:cal 32k enable (16 cycles 32k, count sys clock cycles) [6]:1:at the pos of 32k clock to set 32k timer value [5]:suspend bypass system_timer module [4]:system timer ss enable [3] manual set 32k timer mode [2]:manual set 32k timer 1:write, 0: read [1]:irq mask 1: enable, 0: disable	0x90



Address	Mnemonic	R/W	Function	Default Value
			[0] rsvd	
0x74f	SYS_TIMER_CTRL 1		[1]: timer_en, System Timer busy [2]: rsvd (clk32k_tm) [3]: m_wr_32k_en, busy reading/writing 32k Timer manually [7:4]: rsvd (ss)	0x00

**\*Note:** The lower three bits of address 0x740 is invalid, therefore, the resolution should be 0.5us.

## 6 Interrupt System

### 6.1 Interrupt structure

The interrupting function is applied to manage dynamic program sequencing based on real-time events triggered by timers, pins and etc.

For the TLSR8250F512, there are 24 interrupt sources in all: 16 types are level-triggered interrupt sources (listed in address 0x640~0x641) and 8 types are edge-triggered interrupt sources (listed in address 0x642).

When CPU receives an interrupt request (IRQ) from some interrupt source, it will determine whether to respond to the IRQ. If CPU decides to respond, it pauses current routine and starts to execute interrupt service subroutine. Program will jump to certain code address and execute IRQ commands. After finishing interrupt service subroutine, CPU returns to the breakpoint and continues to execute main function.

### 6.2 Register configuration

Table 6- 1 Register table for Interrupt system

Address	Mnemonic	Type	Description	Reset Value
0x640	MASK_0	RW	Byte 0 interrupt mask, level-triggered type {irq_mix, irq_uart, irq_dfifo, irq_dma, usb_pwdn, time2, time1, time0} [7] irq_mix, i.e. irq_host_cmd [6] irq_uart [5] irq_dfifo [4] irq_dma [3] RSVD (usb_pwdn) [2] time2 [1] time1 [0] time0	0x00
0x641	MASK_1	RW	Byte 1 interrupt mask, level-triggered type {rsvd, irq_pwm, irq_zb_rt, irq_udc[4:0]} [7] rsvd [6] irq_pwm [5] irq_zb_rt [4] RSVD (irq_udc[4]) [3] RSVD (irq_udc[3]) [2] RSVD (irq_udc[2]) [1] RSVD (irq_udc[1]) [0] RSVD (irq_udc[0])	0x00
0x642	MASK_2	RW	Byte 2 interrupt mask, edge-triggered type {rsvd, gpio2risc[1:0], irq_stimer, pm_irq, irq_gpio, usb_reset, usb_250us} [7] rsvd [6] gpio2risc[1] [5] gpio2risc[0] [4] irq_stimer [3] pm_irq_tm	0x00

Address	Mnemonic	Type	Description	Reset Value
			[2] irq_gpio [1] RSVD (usb_reset) [0] RSVD (usb_250us)	
0x643	IRQMODE	RW	[0] interrupt enable [1] reserved (Multi-Address enable)	0x00
0x644	PRIO_0	RW	Byte 0 of priority 1: High priority; 0: Low priority	0x00
0x645	PRIO_1	RW	Byte 1 of priority	0x00
0x646	PRIO_2	RW	Byte 2 of priority	0x00
0x648	IRQSRC_0	R	Byte 0 of interrupt source	0x00
0x649	IRQSRC_1	R	Byte 1 of interrupt source	0x00
0x64a	IRQSRC_2	R	Byte 2 of interrupt source	0x00

### 6.2.1 Enable/Mask interrupt sources

Various interrupt sources could be enabled or masked by registers MASK\_0~MASK\_2 (address 0x640~0x642).

Interrupt sources of level-triggered type:

- ✧ irq\_mix (0x640[7]): I2C Slave mapping mode or SPI Slave interrupt (irq\_host\_cmd)
- ✧ irq\_uart (0x640[6]): UART interrupt
- ✧ irq\_dfifo (0x640[5]): DFIFO interrupt
- ✧ irq\_dma (0x640[4]): DMA interrupt
- ✧ usb\_pwdn (0x640[3]): reserved
- ✧ time2, time1, timer0 (0x640[2]~0x640[0]): Timer2~Timer0 interrupt
- ✧ irq\_pwm (0x641[6]): PWM interrupt
- ✧ irq\_zb\_rt (0x641[5]): Baseband interrupt
- ✧ irq\_udc[4:0] (0x641[4:0]): reserved

Interrupt sources of edge-triggered type:

- ✧ gpio2risc[1:0] (0x642[6]~0x642[5]): gpio2risc[1]~gpio2risc[0] interrupt, please refer to section **7.1.2**.
- ✧ irq\_stimer (0x642[4]): System timer interrupt
- ✧ pm\_irq\_tm (0x642[3]): 32kHz timer wakeup interrupt
- ✧ irq\_gpio (0x642[2]): GPIO interrupt, please refer to section **7.1.2**.
- ✧ usb\_reset (0x642[1]): reserved
- ✧ usb\_250us (0x642[0]): reserved

### 6.2.2 Interrupt mode and priority

Interrupt mode is typically-used mode. Register IRQMODE (address 0x643)[0] should be set as 1b'1 to enable interrupt function.

IRQ tasks could be set as High or Low priority via registers PRIO\_0~PRIO\_2 (address 0x644~0x646). When more than one interrupt sources assert interrupt requests at the same time, CPU will respond depending on respective interrupt priority levels. It's recommended not to modify priority setting.

### 6.2.3 Interrupt source flag

Three bytes in registers IRQSRC\_0~IRQSRC\_2 (address 0x648~0x64a) serve to indicate IRQ sources. Once IRQ occurs from certain source, the corresponding IRQ source flag will be set as "1". User could identify IRQ source by reading address 0x648~0x64a.

When handling edge-triggered type interrupt, the corresponding IRQ source flag needs to be cleared via address 0x64a. Take the interrupt source irq\_gpio for example: First enable the interrupt source by setting address 0x642 bit[2] as 1b'1; then set address 0x643 bit[0] as 1b'1 to enable the interrupt. In interrupt handling function, 24-bit data is read from address 0x648~0x64a to check which IRQ source is valid; if data bit[18] is 1, it means the irq\_gpio IRQ source is valid. Clear this interrupt source by setting address 0x64a bit[2] as 1b'1.

As for level-type interrupt, IRQ interrupt source status needs to be cleared by setting corresponding module status register. Take Timer0 IRQ interrupt source for example: First enable the interrupt source by setting address 0x640 bit[0] as 1b'1; then set address 0x643 bit[0] as 1b'1 to enable the interrupt. In interrupt handling function, 24-bit data is read from address 0x648~0x64a to check which IRQ source is valid; if data bit[0] is 1, it means the Timer0 IRQ source is valid. Register TMR\_STATUS (address 0x623) [0] should be written with 1b'1 to manually clear Timer0 status (refer to section **5.1.1 Register table**).

## 7 Interface

### 7.1 GPIO

The TLSR8250F512ET32 and TLSR8250F512ES16 support up to 17 and 4 GPIOs respectively. All digital IOs can be used as general purpose IOs.

All GPIOs (including PA<0>~PD<7>) have configurable pull-up/pull-down resistor. Please refer to **section 7.1.3 Pull-up/Pull-down resistor** for details.

#### 7.1.1 Basic configuration

##### 7.1.1.1 GPIO lookup table

Table 7- 1 GPIO lookup table 1

Pin	Default function	Pad Function Mux				GPIO Setting						
		Register=2	Register=1	Register=0	Register	Input (R)	IE	OEN	Output	Polarity	DS	Act as GPIO
PWM0_N/ UART_RX/ PA<0>	GPIO	UART_RX	PWM0_N	/	0x5a8[1:0]	0x580[0]	0x581[0]	0x582[0]	0x583[0]	0x584[0]	0x585[0]	0x586[0]
PA<1>	GPIO	/	/	/	0x5a8[3:2]	0x580[1]	0x581[1]	0x582[1]	0x583[1]	0x584[1]	0x585[1]	0x586[1]
SWS/ UART_RTS/ PA<7>	SWS	/	UART_RTS	SWS	0x5a9[7:6]	0x580[7]	0x581[7]	0x582[7]	0x583[7]	0x584[7]	0x585[7]	0x586[7]
PWM3/ UART_RX/ sar_aio<0>/ PB<0>	GPIO	/	UART_RX	PWM3	0x5aa[1:0]	0x588[0]	afe_0x3d [0]	0x58a[0]	0x58b[0]	0x58c[0]	afe_0x3f [0]	0x58e[0]
PWM4/ UART_TX/ sar_aio<1>/ PB<1>	GPIO	/	UART_TX	PWM4	0x5aa[3:2]	0x588[1]	afe_0x3d [1]	0x58a[1]	0x58b[1]	0x58c[1]	afe_0x3f [1]	0x58e[1]
PWM4/ sar_aio<4>/ PB<4>	GPIO	/	PWM4	/	0x5ab[1:0]	0x588[4]	afe_0x3d [4]	0x58a[4]	0x58b[4]	0x58c[4]	afe_0x3f [4]	0x58e[4]
PWM5/ sar_aio<5>/ PB<5>	GPIO	/	PWM5	/	0x5ab[3:2]	0x588[5]	afe_0x3d [5]	0x58a[5]	0x58b[5]	0x58c[5]	afe_0x3f [5]	0x58e[5]
SPI_DI/ UART_RTS/ sar_aio<6>/ PB<6>	SPI_DI	UART_RTS	SPI_DI	/	0x5ab[5:4]	0x588[6]	afe_0x3d [6]	0x58a[6]	0x58b[6]	0x58c[6]	afe_0x3f [6]	0x58e[6]
SPI_DO/ UART_RX/ sar_aio<7>/ PB<7>	SPI_DO	UART_RX	SPI_DO	/	0x5ab[7:6]	0x588[7]	afe_0x3d [7]	0x58a[7]	0x58b[7]	0x58c[7]	afe_0x3f [7]	0x58e[7]

Pin	Default function	Pad Function Mux				GPIO Setting						
		Register=2	Register=1	Register=0	Register	Input (R)	IE	OEN	Output	Polarity	DS	Act as GPIO
I2C_SDA/ PWM4_N/ UART_RTS/ PC<0>	GPIO	UART_RTS	PWM4_N	I2C_SDA	0x5ac[1:0]	0x590[0]	afe_0x40 [0]	0x592[0]	0x593[0]	0x594[0]	afe_0x42 [0]	0x596[0]
I2C_SCK/ PWM1_N/ PWM0/ PC<1>	GPIO	PWM0	PWM1_N	I2C_SCK	0x5ac[3:2]	0x590[1]	afe_0x40 [1]	0x592[1]	0x593[1]	0x594[1]	afe_0x42 [1]	0x596[1]
PWM0/ I2C_SDA/ XC32K_O/ PC<2>	GPIO	I2C_SDA	/	PWM0	0x5ac[5:4]	0x590[2]	afe_0x40 [2]	0x592[2]	0x593[2]	0x594[2]	afe_0x42 [2]	0x596[2]
PWM1/ UART_RX/ I2C_SCK/ XC32K_I/ PC<3>	GPIO	I2C_SCK	UART_RX	PWM1	0x5ac[7:6]	0x590[3]	afe_0x40 [3]	0x592[3]	0x593[3]	0x594[3]	afe_0x42 [3]	0x596[3]
PWM2/ UART_CTS/ PWM0_N/ sar_aio<8>/ PC<4>	GPIO	PWM0_N	UART_CTS	PWM2	0x5ad[1:0]	0x590[4]	afe_0x40 [4]	0x592[4]	0x593[4]	0x594[4]	afe_0x42 [4]	0x596[4]
PWM3_N/ UART_RX/ sar_aio<9>/ PC<5>	GPIO	/	UART_RX	PWM3_N	0x5ad[3:2]	0x590[5]	afe_0x40 [5]	0x592[5]	0x593[5]	0x594[5]	afe_0x42 [5]	0x596[5]
SPI_CN/ PWM3/ PD<2>	SPI_CN	PWM3	/	SPI_CN	0x5ae[5:4]	0x598[2]	0x599[2]	0x59a[2]	0x59b[2]	0x59c[2]	0x59d[2]	0x59e[2]
PWM1_N/ PD<3>	GPIO	/	/	PWM1_N	0x5ae[7:6]	0x598[3]	0x599[3]	0x59a[3]	0x59b[3]	0x59c[3]	0x59d[3]	0x59e[3]
SWM/ PWM2_N/ PD<4>	GPIO	PWM2_N	/	SWM	0x5af[1:0]	0x598[4]	0x599[4]	0x59a[4]	0x59b[4]	0x59c[4]	0x59d[4]	0x59e[4]
SPI_CK/ /PD<7>	SPI_CK	/	/	SPI_CK	0x5af[7:6]	0x598[7]	0x599[7]	0x59a[7]	0x59b[7]	0x59c[7]	0x59d[7]	0x59e[7]

**\*Notes:**

- (1) IE: Input enable, high active. 1: enable input, 0: disable input.
- (2) OEN: Output enable, low active. 0: enable output, 1: disable output.
- (3) Register: Configure multiplexed functions in “Pad Function Mux” column.
- (4) Output: configure GPO output.
- (5) Input: read GPI input.

- (6) DS: Drive strength. Default: 1 (high DS level).
- (7) Act as GPIO: enable (1) or disable (0) GPIO function.
- (8) Polarity: see section 7.1.2 Connection relationship between GPIO and related modules.
- (9) Priority: "Act as GPIO" has the highest priority. To configure as multiplexed function, disable GPIO function first.
- (10) afe\_0x3d, afe\_0x3f, afe\_0x40 and afe\_0x42 marked in red color are analog registers; others are digital registers.
- (11) For all unused GPIOs, corresponding "IE" must be set as 0.
- (12) When SWS/PA<7> "IE" is set as 1, this pin must be fixed as pull-up/pull-down state (float state is not allowed).
- (13) To use SAR ADC pin function, please refer to corresponding module section.

### 7.1.1.2 Multiplexed functions

Each pin listed in Table 7-1 acts as the function in the "Default Function" column by default.

- ✧ PA<7> acts as SWS function by default.
- ✧ PB<6:7>, PD<2,7> act as SPI function by default.
- ✧ The other digital IOs act as GPIO function by default.

If a pin with multiplexed functions does not act as GPIO function by default, to use it as GPIO, first set the bit in "Act as GPIO" column as 1b'1. After GPIO function is enabled, if the pin is used as output, both the bits in "IE" and "OEN" columns should be set as 1b'0, then set the register value in the "Output" column; if the pin is used as input, both the bits in "IE" and "OEN" columns should be set as 1b'1, and the input data can be read from the register in the "Input" column.

To use a pin as certain multiplexed function (neither the default function nor GPIO function), first clear the bit in "Act as GPIO" column to disable GPIO function, and then configure "Register" in "Pad Function Mux" column to enable multiplexed function correspondingly.

**Example 1:** PWM0\_N/ UART\_RX/ PA<0>.

- (1) The pin acts as GPIO function by default.
  - ✧ If the pin is used as general output, both address 0x581[0] (IE) and 0x582[0] (OEN) should be set as 1b'0, then configure address 0x583[0] (Output).
  - ✧ If the pin is used as general input, both address 0x581[0] (IE) and 0x582[0] (OEN) should be set as 1b'1, and the input data can be read from address 0x580[0] (Input).
- (2) To use the pin as PWM0\_N function, address 0x586[0] (Act as GPIO) should be set as 1b'0, and 0x5a8[1:0] (Register) should be set as 2b'01.
- (3) To use the pin as UART\_RX function, address 0x586[0] (Act as GPIO) should be set as 1b'0, and 0x5a8[1:0] (Register) should be set as 2b'10.

**Example 2:** SWS/ UART\_RTS/ PA<7>.

- (1) The pin acts as SWS function by default.
- (2) To use it as GPIO function, first set address 0x586[7] (Act as GPIO) as 1b'1.
  - ✧ If the pin is used as general output, both address 0x581[7] (IE) and 0x582[7] (OEN) should be set as 1b'0, then configure address 0x583[7] (Output).
  - ✧ If the pin is used as general input, both address 0x581[7] (IE) and 0x582[7] (OEN) should be set to 1b'1, and the input data can be read from address 0x580[7] (Input).
- (3) To use it as UART\_RTS function, set address 0x586[7] (Act as GPIO) as 1b'0, and set 0x5a9[7:6] (Register) to 2b'01.

I2C can also be multiplexed with SPI interface, i.e. I2C\_SDA/I2C\_SCK can be multiplexed with SPI\_DI (DI)/SPI\_CK (CK) respectively.

To select multiplexed SPI/I2C function, please follow the steps below:

- 1) Disable GPIO function by setting corresponding "Act as GPIO" as 1b'0.
- 2) Select SPI/I2C function by setting corresponding "Register".
- 3) Address 0x5b6 serve to select SPI or I2C output.
- 4) Address 0x5b7 serve to select SPI input or I2C input.

Table 7- 2 Select multiplexed SPI/I2C

Pin with multiplexed SPI/I2C	Act as GPIO	Register	SPI Input Select	I2C Input Select	SPI/I2C Output Select
SPI_DI/UART_RTS/ sar_aio<6>/PB<6>	0x58e[6]=0 Disable GPIO	0x5ab[5:4]=1 Select SPI_DI (I2C_SDA) (default function)	5b7[2] 1: as SPI input. 0: not as SPI input.	5b7[6] 1: as I2C input. 0: not as I2C input.	0x5b6[6] 1: as SPI/I2C output 0: not as SPI/I2C output
SPI_CK/ PD<7>	0x59e[7] =0 Disable GPIO	0x5af[7:6] =0 Select SPI_CK (I2C_SCK) (default function)	5b7[3] 1: as SPI input. 0: not as SPI input.	5b7[7] 1: as I2C input. 0: not as I2C input.	0x5b6[7] 1: as SPI/I2C output 0: not as SPI/I2C output

**7.1.1.3 Drive strength**

The registers in the "DS" column are used to configure the corresponding pin's driving strength: "1" indicates maximum drive level, while "0" indicates minimal drive level.

The "DS" configuration will take effect when the pin is used as output. It's set as the strongest driving level by default. In actual applications, driving strength can be decreased to lower level if necessary.

- ✧ PA<7>, PB<0:1>: maximum=8mA ("DS"=1), minimum=4mA ("DS"=0)
- ✧ PB<4:7>: maximum=16mA ("DS"=1), minimum=12mA ("DS"=0)
- ✧ Other GPIOs (PA<0:1>, PC<0:5>, PD<2:4> and PD<7>): maximum=4mA ("DS"=1), minimum=2mA ("DS"=0)



### 7.1.2 Connection relationship between GPIO and related modules

GPIO can be used to generate GPIO interrupt signal for interrupt system, counting or control signal for Timer/Counter module, or GPIO2RISC interrupt signal for interrupt system.

For the “Exclusive Or (XOR)” operation result for input signal from any GPIO pin and respective “Polarity” value, on one hand, it takes “And” operation with “irq” and generates GPIO interrupt request signal; on the other hand, it takes “And” operation with “m0/m1/m2”, and generates counting signal in Mode 1 or control signal in Mode 2 for Timer0/Timer1/Timer2, or generates GPIO2RISC[0]/GPIO2RISC[1] interrupt request signal.

GPIO interrupt request signal =  $| ((input \wedge polarity) \& irq);$

Counting (Mode 1) or control (Mode 2) signal for Timer0 =  $| ((input \wedge polarity) \& m0);$

Counting (Mode 1) or control (Mode 2) signal for Timer1 =  $| ((input \wedge polarity) \& m1);$

Counting (Mode 1) or control (Mode 2) signal for Timer2 =  $| ((input \wedge polarity) \& m2);$

GPIO2RISC[0] interrupt request signal =  $| ((input \wedge polarity) \& m0);$

GPIO2RISC[1] interrupt request signal =  $| ((input \wedge polarity) \& m1);$

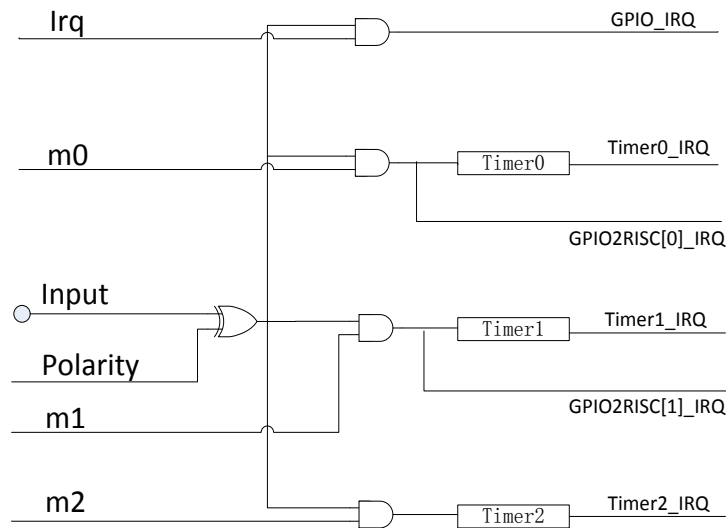

Figure 7- 1 Logic relationship between GPIO and related modules

Please refer to Table 7- 3 and Table 6- 1 to learn how to configure GPIO for interrupt system or Timer/Counter (Mode 1 or Mode 2).

(1) First enable GPIO function, enable IE and disable OEN. Please see section **7.1.1 Basic configuration** .

(2) GPIO IRQ signal:

Select GPIO interrupt trigger edge (positive edge or negative edge) via configuring “**Polarity**”, and set corresponding GPIO interrupt enabling bit “**Irq**”.

Then set address 0x5b5[3] (irq\_enable) to enable GPIO IRQ.

Finally enable GPIO interrupt (irq\_gpio) via address 0x642[2].

User can read addresses 0x5e0 ~ 0x5e3 to see which GPIO asserts GPIO interrupt request signal. Note: 0x5e0[7:0] --> PA<7>~PA<0>, 0x5e1[7:0] --> PB<7>~PB<0>, 0x5e2[7:0] --> PC<7>~PC<0>, 0x5e3[7:0] --> PD<7>~PD<0>.

(3) Timer/Counter counting or control signal:

Configure “**Polarity**”. In Timer Mode 1, it determines GPIO edge when Timer Tick counting increases. In Timer Mode 2, it determines GPIO edge when Timer Tick starts counting.

Then set “**m0/m1/m2**” to specify the GPIO which generates counting signal (Mode 1)/control signal (Mode 2) for Timer0/Timer1/Timer2.

User can read addresses 0x5e8~0x5eb/0x5f0~0x5f3/0x5f8~0x5fb to see which GPIO asserts counting signal (in Mode 1) or control signal (in Mode 2) for Timer0/Timer1/Timer2. Note: Timer0: 0x5e8[7:0] --> PA<7>~PA<0>, 0x5e9[7:0] --> PB<7>~PB<0>, 0x5ea[7:0] --> PC<7>~PC<0>, 0x5eb[7:0] --> PD<7>~PD<0>; Timer1: 0x5f0[7:0] --> PA<7>~PA<0>, 0x5f1[7:0] --> PB<7>~PB<0>, 0x5f2[7:0] --> PC<7>~PC<0>, 0x5f3[7:0] --> PD<7>~PD<0>; Timer2: 0x5f8[7:0] --> PA<7>~PA<0>, 0x5f9[7:0] --> PB<7>~PB<0>, 0x5fa[7:0] --> PC<7>~PC<0>, 0x5fb[7:0] --> PD<7>~PD<0>.

(4) GPIO2RISC IRQ signal:

Select GPIO2RISC interrupt trigger edge (positive edge or negative edge) via configuring “**Polarity**”, and set corresponding GPIO enabling bit “**m0**”/“**m1**”.

Enable GPIO2RISC[0]/GPIO2RISC[1] interrupt, i.e. “gpio2risc[0]” (address 0x642[5]) / “gpio2risc[1]”(address 0x642[6]).

Table 7- 3GPIO lookup table2

Pin	Input (R)	Polarity 1: active low 0: active high	Irq	m0	m1	m2
PA<0>	0x580[0]	0x584[0]	0x587[0]	0x5b8[0]	0x5c0[0]	0x5c8[0]
PA<1>	0x580[1]	0x584[1]	0x587[1]	0x5b8[1]	0x5c0[1]	0x5c8[1]
PA<7>	0x580[7]	0x584[7]	0x587[7]	0x5b8[7]	0x5c0[7]	0x5c8[7]
PB<0>	0x588[0]	0x58c[0]	0x58f[0]	0x5b9[0]	0x5c1[0]	0x5c9[0]
PB<1>	0x588[1]	0x58c[1]	0x58f[1]	0x5b9[1]	0x5c1[1]	0x5c9[1]
PB<4>	0x588[4]	0x58c[4]	0x58f[4]	0x5b9[4]	0x5c1[4]	0x5c9[4]
PB<5>	0x588[5]	0x58c[5]	0x58f[5]	0x5b9[5]	0x5c1[5]	0x5c9[5]
PB<6>	0x588[6]	0x58c[6]	0x58f[6]	0x5b9[6]	0x5c1[6]	0x5c9[6]
PB<7>	0x588[7]	0x58c[7]	0x58f[7]	0x5b9[7]	0x5c1[7]	0x5c9[7]
PC<0>	0x590[0]	0x594[0]	0x597[0]	0x5ba[0]	0x5c2[0]	0x5ca[0]
PC<1>	0x590[1]	0x594[1]	0x597[1]	0x5ba[1]	0x5c2[1]	0x5ca[1]
PC<2>	0x590[2]	0x594[2]	0x597[2]	0x5ba[2]	0x5c2[2]	0x5ca[2]
PC<3>	0x590[3]	0x594[3]	0x597[3]	0x5ba[3]	0x5c2[3]	0x5ca[3]
PC<4>	0x590[4]	0x594[4]	0x597[4]	0x5ba[4]	0x5c2[4]	0x5ca[4]
PC<5>	0x590[5]	0x594[5]	0x597[5]	0x5ba[5]	0x5c2[5]	0x5ca[5]

Pin	Input (R)	Polarity 1: active low 0: active high	Irq	m0	m1	m2
PD<2>	0x598[2]	0x59c[2]	0x59f[2]	0x5bb[2]	0x5c3[2]	0x5cb[2]
PD<3>	0x598[3]	0x59c[3]	0x59f[3]	0x5bb[3]	0x5c3[3]	0x5cb[3]
PD<4>	0x598[4]	0x59c[4]	0x59f[4]	0x5bb[4]	0x5c3[4]	0x5cb[4]
PD<7>	0x598[7]	0x59c[7]	0x59f[7]	0x5bb[7]	0x5c3[7]	0x5cb[7]

### 7.1.3 Pull-up/Pull-down resistor

All GPIOs (including PA<0>~PD<7>) support configurable pull-up resistor of rank x1 and x100 or pull-down resistor of rank x10 which are all disabled by default. Analog registers afe\_0x0e<7:0>~afe\_0x15<7:0> serve to control the pull-up/pull-down resistor for each GPIO.

Take the PA<0> for example: Setting analog register afe\_0x0e<1:0> to 2b'01/2b'11/2b'10 is to respectively enable pull-up resistor of rank x100/pull-up resistor of rank x1/pull-down resistor of rank x10 for PA<0>; Clearing the two bits (default value) disables pull-up and pull-down resistor for PA<0>.

Table 7- 4 Analog registers for pull-up/pull-down resistor control

Address	Mnemonic	Default	Description
<b>Rank</b>		<b>Typical value (depend on actual application)</b>	
	x1	18kohm	
	x10	160kohm	
	x100	1Mohm	
afe_0x0e<7:0>	a_sel<7:0>	00000000	PA<3:0> pull up and down select: <3:2>: PA<1> <1:0>: PA<0> 00: Null 01: x100 pull up 10: x10 pull down 11: x1 pull up
afe_0x0f<7:0>	a_sel<15:8>	00000000	PA<7:4> pull up and down select: <7:6>: PA<7> 00: Null 01: x100 pull up 10: x10 pull down 11: x1 pull up
afe_0x10<7:0>	b_sel<7:0>	00000000	PB<3:0> pull up and down select: <3:2>: PB<1> <1:0>: PB<0> 00: Null 01: x100 pull up 10: x10 pull down 11: x1 pull up

Address	Mnemonic	Default	Description
afe_0x11<7:0>	b_sel<15:8>	00000000	PB<7:4> pull up and down select: <7:6>: PB<7> <5:4>: PB<6> <3:2>: PB<5> <1:0>: PB<4> 00: Null 01: x100 pull up 10: x10 pull down 11: x1 pull up
afe_0x12<7:0>	c_sel<7:0>	00000000	PC<3:0> pull up and down select: <7:6>: PC<3> <5:4>: PC<2> <3:2>: PC<1> <1:0>: PC<0> 00: Null 01: x100 pull up 10: x10 pull down 11: x1 pull up
afe_0x13<7:0>	c_sel<15:8>	00000000	PC<7:4> pull up and down select: <3:2>: PC<5> <1:0>: PC<4> 00: Null 01: x100 pull up 10: x10 pull down 11: x1 pull up
afe_0x14<7:0>	d_sel<7:0>	00000000	PD<3:0> pull up and down select: <7:6>: PD<3> <5:4>: PD<2> 00: Null 01: x100 pull up 10: x10 pull down 11: x1 pull up
afe_0x15<7:0>	d_sel<15:8>	00000000	PD<7:4> pull up and down select: <7:6>: PD<7> <1:0>: PD<4> 00: Null 01: x100 pull up 10: x10 pull down 11: x1 pull up

## 7.2 SWM and SWS

The TLSR8250F512 supports Single Wire interface. SWM (Single Wire Master) and SWS (Single Wire Slave) represent the master and slave device of the single wire communication system developed by Telink. The maximum data rate can be up to 2Mbps.

### 7.3 I2C

The TLSR8250F512 embeds I2C hardware module, which could act as Master mode or Slave mode. I2C is a popular inter-IC interface requiring only 2 bus lines, a serial data line (SDA) and a serial clock line (SCL).

#### 7.3.1 Communication protocol

Telink I2C module supports standard mode (100kbps) and Fast-mode (400kbps) with restriction that system clock must be by at least 10x of data rate.

Two wires, SDA and SCL (SCK) carry information between Master device and Slave device connected to the bus. Each device is recognized by unique address (ID). Master device is the device which initiates a data transfer on the bus and generates the clock signals to permit that transfer. Slave device is the device addressed by a Master.

Both SDA and SCL are bidirectional lines connected to a positive supply voltage via a pull-up resistor. It's recommended to use external 3.3kohm pull-up resistor. For standard mode, the internal pull-up resistor of rank x1 can be used instead of the external 3.3kohm pull-up.

When the bus is free, both lines are HIGH. It's noted that data in SDA line must keep stable when clock signal in SCL line is at high level, and level state in SDA line is only allowed to change when clock signal in SCL line is at low level.

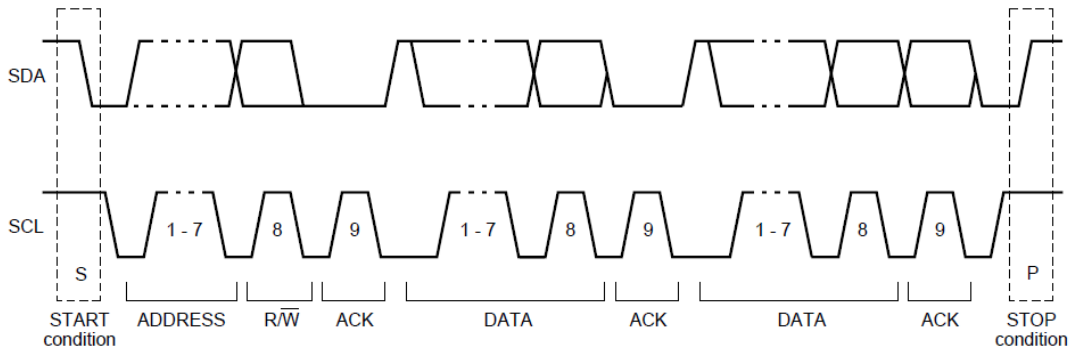

Figure 7-2 I2C timing chart

#### 7.3.2 Register table

Table 7-5 Register configuration for I2C

Address	Name	R/W	Description	Reset Value
0x00	I2CSP	RW	I2C master clock speed	0x1f
0x01	I2C_ID	RW	[7:1] I2C ID	0x5c
0x02	I2CMST	RW	[0]: master busy [1]: master packet busy [2]: master received status 0 for ACK; 1 for NAK	0x00
0x03	I2CSCT0	RW	[0]: address auto increase enable [1]: I2C master enable [2]: enable Mapping Mode [3]: r_clk_stretch_en, suspend	0x01

Address	Name	R/W	Description	Reset Value
			transmission by pulling SCL down to low level, and continue transmission after SCL is released to high level	
0x04	I2CAD	RW	[7:0] data buffer in master mode	0x5a
0x05	I2CDW	RW	[7:0] Data buffer in master mode	0xf1
0x06	I2CDR	RW	[7:0] Data buffer for Read or Write in master mode	0x00
0x07	I2CSCT1	RW	[0]: launch ID cycle [1]: launch address cycle (send I2CAD data) [2]: launch data write cycle [3]: launch data read cycle For Master Write: 0: I2CAD&I2CDW, 1: I2CAD&I2CDW&I2CDR) To write 3 bytes: bit[3]=1; To write 2 bytes: bit[3]=0. For Master Read: always 1. [4]: launch start cycle [5]: launch stop cycle [6]: enable read ID [7]: enable ACK in read command	0x00
0xe0	I2CMAP_HADR	R	[6:0] I2C read address	0x00
0xe1	HOSR_ADR_L	RW	Low byte of Mapping mode buffer address	0x80
0xe2	HOSR_ADR_M	RW	Middle byte of Mapping mode buffer address	0xd7
0xe3	HOSR_ADR_H	RW	High byte of Mapping mode buffer address	0x00
0xe4	I2CMAP_HOST	RW	[0]: host_cmd_irq_o, I2C host operation has happened. Write 1 to clear. [1]: host_rd_tag_o, I2C host operation has happened and is read operation. Write 1 to clear.	0x00

### 7.3.3 I2C Slave mode

I2C module of the TLSR8250F512 acts as Slave mode by default. I2C slave address can be configured via register I2C\_ID (address 0x01) [7:1].

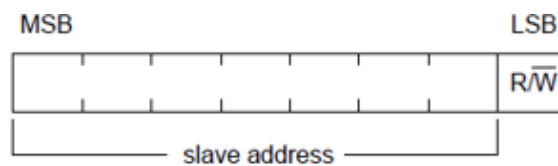

Figure 7- 3 Byte consisted of slave address and R/W flag bit

I2C slave mode supports two sub modes including Direct Memory Access (DMA) mode and Mapping mode, which is selectable via address 0x03[2].

In I2C Slave mode, Master could initiate transaction anytime. I2C slave module will reply with ACK automatically. To monitor the start of I2C transaction, user could set interrupt from GPIO for SCA or SCL.

### 7.3.3.1 DMA mode

In DMA mode, other devices (Master) could access (read/write) designated address in Register and/or SRAM of the TLSR8250F512 according to I2C protocol. I2C module of the TLSR8250F512 will execute the read/write command from I2C master automatically. But user needs to notice that the system clock shall be at least 10x faster than I2C bit rate.

The access address designated by Master is offset by 0x800000. In the TLSR8250F512, Register address starts from 0x800000 and SRAM address starts from 0x840000. For example, if Addr High (AddrH) is 0x04, Addr Middle (AddrM) is 0x00, and Addr Low (AddrL) is 0xcc, the real address of accessed data is 0x8400cc.

In DMA mode, Master could read/write data byte by byte. The designated access address is initial address and it supports auto increment by setting address 0x03[0] to 1b'1.

#### Read Format in DMA mode

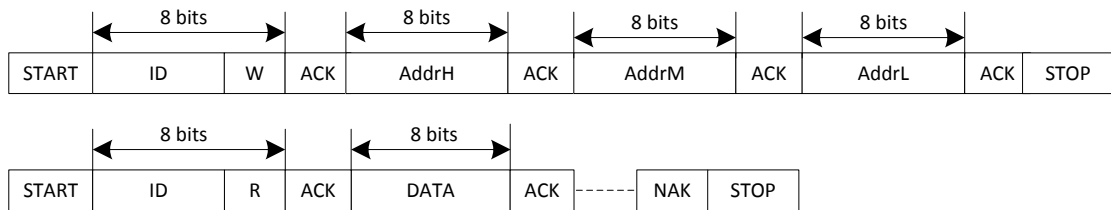

Figure 7- 4 Read format in DMA mode

#### Write Format in DMA mode



Figure 7- 5 Write format in DMA mode

### 7.3.3.2 Mapping mode

Mapping mode could be enabled via setting register I2CSCT0 (address 0x03)[2] to 1b'1.

In Mapping mode, data written and read by I2C master will be redirected to specified 128-byte buffer in SRAM. User could specify the initial address of the buffer by configuring registers HOSR\_ADR\_L (address 0xe1, lower byte), HOSR\_ADR\_M (address 0xe2, middle byte) and HOSR\_ADR\_H (address 0xe3, higher byte). The first 64-byte buffer is for written data and following 64-byte buffer is for read data. Every time the data access will start from the beginning of the Write-buffer/Read-buffer after I2C stop condition occurs. The last accessed data address could be checked in register I2CMAP\_HADR (address 0xe0) [6:0] which is only updated after I2C STOP occurs.

### Read Format in mapping mode

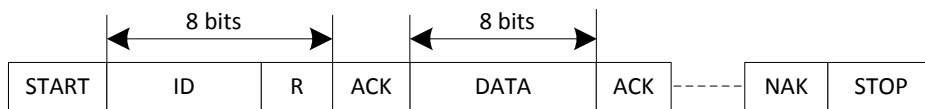

Figure 7- 6 Read format in Mapping mode

### Write Format in mapping mode

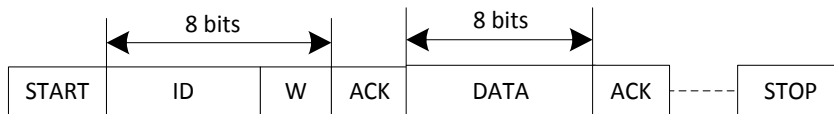

Figure 7- 7 Write format in Mapping mode

### 7.3.4 I2C Master mode

Address 0x03[1] should be set to 1b'1 to enable I2C master mode for the TLSR8250F512.

Address 0x00 serves to set I2C Master clock:  $F_{I2C} = (\text{System Clock} / (4 * \text{clock speed configured in address 0x00}))$ .

A complete I2C protocol contains START, Slave Address, R/W bit, data, ACK and STOP. Slave address could be configured via address 0x01[7:1].

I2C Master (i.e. I2C module of the TLSR8250F512) could send START, Slave Address, R/W bit, data and STOP cycle by configuring address 0x07. I2C master will send enabled cycles in the correct sequence.

Address 0x02 serves to indicate whether Master/Master packet is busy, as well as Master received status. Bit[0] will be set to 1 when one byte is being sent, and the bit can be automatically cleared after a start signal/ address byte/acknowledge signal/data /stop signal is sent. Bit[1] is set to 1 when the start signal is sent, and the bit will be automatically cleared after the stop signal is sent. Bit[2] indicates whether to succeed in sending acknowledgement signal.



#### 7.3.4.1 I2C Master Write transfer

I2C Master has 3-byte buffer for write data, which are I2CAD (0x04), I2CDW (0x05) and I2CDR (0x06). Write transfer will be completed by I2C master module.

For example, to implement an I2C write transfer with 3-byte data, which contains START, Slave Address, Write bit, ack from Slave, 1st byte, ack from slave, 2nd byte, ack from slave, 3rd byte, ack from slave and STOP, user needs to configure I2C slave address to I2C\_ID (0x01) [7:1], 1st byte data to I2CAD, 2nd byte data to I2CDW and 3rd byte to I2CDR. To start I2C write transfer, I2CSCT1 (0x07) is configured to 0x3f (0011 1111). I2C Master will launch START, Slave address, Write bit, load ACK to I2CMST (0x02) [2], send I2CAD data, load ACK to I2CMST[2], send I2CDW data, load ACK to I2CMST[2], send I2CDR data, load ACK to I2CMST[2] and then STOP sequentially.

For I2C write transfer whose data are more than 3 bytes, user could split the cycles according to I2C protocol.

#### 7.3.4.2 I2C Master Read transfer

I2C Master has one byte buffer for read data, which is I2CDR (0x06). Read transfer will be completed by I2C Master.

For example, to implement an I2C read transfer with 1 byte data, which contains START, Slave Address, Read bit, Ack from Slave, 1<sup>st</sup> byte from Slave, Ack by master and STOP, user needs to configure I2C slave address to I2C\_ID (0x01) [7:1]. To start I2C read transfer, I2CSCT1 (0x07) is configured to 0xf9 (1111 1001). I2C Master will launch START, Slave address, Read bit, load ACK to I2CMST (0x02) [2], load data to I2CDR, reply ACK and then STOP sequentially.

For I2C read transfer whose data are more than 1 byte, user could split the cycles according to I2C protocol.

#### 7.3.5 I2C and SPI Usage

I2C hardware and SPI hardware modules in the chip share part of the hardware, as a result, when both hardware interfaces are used, the restrictions listed within this section need to be taken into consideration.

I2C and SPI hardware cannot be used as Slave at the same time.

The other cases are supported, including:

- ✧ I2C Slave and SPI Master can be used at the same time.
- ✧ I2C Master and SPI Slave can be used at the same time.
- ✧ I2C and SPI can be used as Master at the same time.

Please refer to corresponding SDK instructions for details.

## 7.4 SPI

The TLSR8250F512 embeds SPI (Serial Peripheral interface), which could act as Master mode or Slave mode. SPI is a high-speed, full-duplex and synchronous communication bus requiring 4 bus lines including a chip select (CS) line, a data input (DI) line, a data output (DO) line and a clock (CK) line.

### 7.4.1 Register table

Table 7- 6 Register configuration for SPI

Address	Name	R/W	Description	Reset Value
0x08	SPIDAT	RW	[7:0]: SPI data access	0x00
0x09	SPICT	RW	[0]: mst_csn, control SPI_CSN output when SPI acts as Master [1]: enable master mode [2]: spi data output disable [3]: 1 for read command; 0 for write command [4]: address auto increase [5]: share_mode [6]: busy status	0x11
0x0a	SPISP	RW	[6:0]: SPI clock speed [7]: SPI function mode, p_csn, p_scl, p_sda and p_sdo function as SPI if 1	0x05
0x0b	SPIMODE	RW	[0]: inverse SPI clock output [1]: data delay half clk	0x00

### 7.4.2 SPI Master mode

SPI for the TLSR8250F512 supports both master mode and slave mode and acts as slave mode by default. Address 0x09 bit[1] should be set to 1b'1 to enable SPI Master mode. Register SPISP is to configure SPI pin and clock: setting address 0x0a bit[7] to 1 is to enable SPI function mode, and corresponding pins can be used as SPI pins; SPI clock = system clock/((clock speed configured in address 0x0a bit[6:0] +1)\*2).

Address 0x08 serves as the data register. One reading/writing operation of 0x08 enables the SPI\_CK pin to generate 8 SPI clock cycles.

Telink SPI supports four standard working modes: Mode 0~Mode 3. Register SPIMODE (address 0x0b) serves to select one of the four SPI modes:

Table 7- 7 SPI Master mode

SPI mode	CPOL/CPHA	SPIMODE register (Address 0x0b)
Mode 0	CPOL=0, CPHA=0	bit[0]=0, bit[1]=0
Mode 1	CPOL=0, CPHA=1	bit[0]=0, bit[1]=1
Mode 2	CPOL=1, CPHA=0	bit[0]=1, bit[1]=0
Mode 3	CPOL=1, CPHA=1	bit[0]=1, bit[1]=1
CPOL: Clock Polarity		

SPI mode	CPOL/CPHA	SPI MODE register (Address 0x0b)
When CPOL=0, SPI_CLK keeps low level in idle state; When CPOL=1, SPI_CLK keeps high level in idle state. CPHA: Clock Phase When CPHA=0, data is sampled at the first edge of clock period When CPHA=1, data is sampled at the latter edge of clock period		

Address 0x09 bit[0] is to control the CS line: when the bit is set to 1, the CS level is high; when the bit is cleared, the CS level is low.

Address 0x09 bit[2] is the disabling bit for SPI Master output. When the bit is cleared, MCU writes data into address 0x08, then the SPI\_DO pin outputs the data bit by bit during the 8 clock cycles generated by the SPI\_CK pin. When the bit is set to 1b'1, SPI\_DO output is disabled.

Address 0x09 bit[3] is the enabling bit for SPI Master reading data function. When the bit is set to 1b'1, MCU reads the data from address 0x08, then the input data from the SPI\_DI pin is shifted into address 0x08 during the 8 clock cycles generated by the SPI\_CK pin. When the bit is cleared, SPI Master reading function is disabled.

Address 0x09[5] is the enabling bit for share mode, i.e. whether SPI\_DI and SPI\_DO share one common line.

Users can read address 0x09 bit[6] to get SPI busy status, i.e. whether the 8 clock pulses have been sent.

### 7.4.3 SPI Slave mode

SPI for the TLSR8250F512 acts as slave mode by default. SPI Slave mode supports DMA. User could access registers of the TLSR8250F512 by SPI interface. It's noted that system clock of TLSR8250F512 shall be at least 5x faster than SPI clock for reliable connection. Address 0x0a should be written with data 0xa5 by the SPI host to activate SPI slave mode. SPI slave only supports Mode0 and Mode3.

Table 7- 8SPI Slave mode

SPI slave mode	CPOL/CPHA
Mode 0	CPOL=0, CPHA=0
Mode 3	CPOL=1, CPHA=1
Receive data at positive edge of SPI MCLK clock. Send data at negative edge of SPI MCLK clock.	

Address 0x09[4] is dedicated for SPI Slave mode and indicates address auto increment. SPI write command format and read command format are illustrated in Figure 7-8:

### SPI Write Format

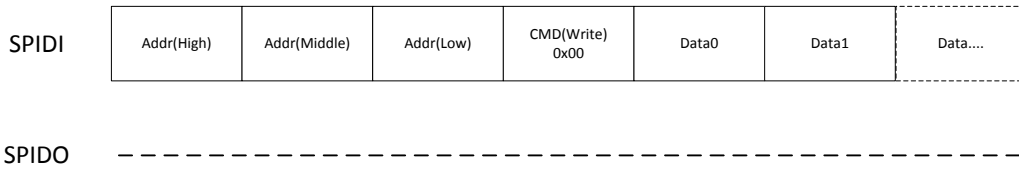

### SPI Read Format



Figure 7- 8 SPI write/read command format

#### 7.4.4 I2C and SPI Usage

I2C hardware and SPI hardware modules in the chip share part of the hardware, as a result, when both hardware interfaces are used, certain restrictions apply.

See **Section 7.3.5 I2C and SPI Usage** for detailed instructions.

#### 7.5 UART

The TLSR8250F512 embeds UART (Universal Asynchronous Receiver/Transmitter) to implement full-duplex transmission and reception via UART TX and RX interface. Both TX and RX interface are 4-layer FIFO (First In First Out) interface.

Hardware flow control is supported via RTS and CTS.

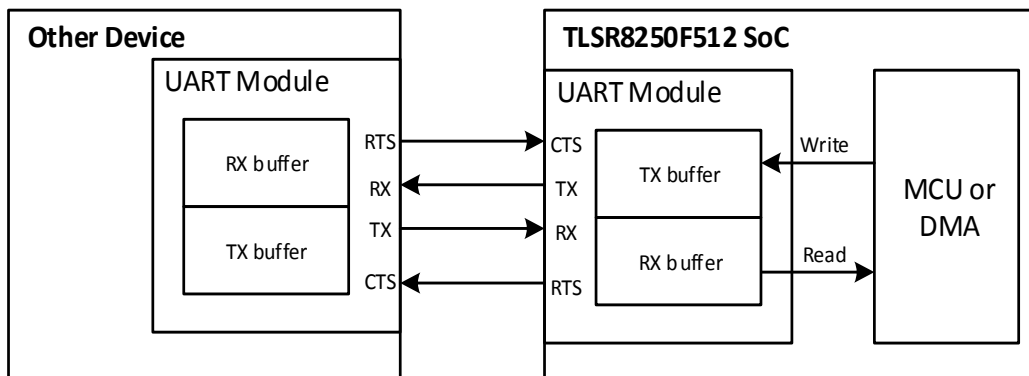

Figure 7- 9 UART communication

As shown in Figure 7-9, data to be sent is first written into TX buffer by MCU or DMA, then UART module transmits the data from TX buffer to other device via pin TX. Data to be read from other device is first received via pin RX and sent to RX buffer, then the data is read by MCU or DMA.

If RX buffer of the TLSR8250F512 UART is close to full, the TLSR8250F512 will send a signal (configurable high or low level) via pin RTS to inform other device that it should stop sending data. Similarly, if the TLSR8250F512 receives a signal from pin CTS, it indicates that RX buffer of other device is close to full and the TLSR8250F512 should stop sending data.

Table 7- 9 Register configuration for UART

Address	Name	R/W	Description	Reset Value
0x90	UART_DATA_BUF0	RW	write/read buffer[7:0]	0x00
0x91	UART_DATA_BUF1	RW	Write/read buffer[15:8]	0x00
0x92	UART_DATA_BUF2	RW	Write/read buffer[23:16]	0x00
0x93	UART_DATA_BUF3	RW	Write/read buffer[31:24]	0x00
0x94	UART_CLK_DIV_L	RW	[7:0]: uart clk div register uart_clk_div[7:0]	0xff
0x95	UART_CLK_DIV_H	RW	[6:0]: uart clk div register uart_clk_div[14:8] uart_sclk = sclk/(uart_clk_div[14:0]+1) [7]: uart_clk_div[15] 1: enable clock divider, 0: disable.	0x0f
0x96	UART_CTRL0	RW	[3:0] bwpc, bit width, should be larger than 2 Baudrate = uart_sclk/(bwpc+1) [4] rx dma enable [5] tx dma enable [6] rx interrupt enable [7]tx interrupt enable	0x0f
0x97	UART_CTRL1	RW	[0] cts select, 0: cts_i, 1: cts_i inverter [1]:cts enable, 1: enable, 0, disable [2]:Parity, 1: enable, 0 :disable [3]: even Parity or odd [5:4]: stop bit 00: 1 bit, 01, 1.5bit 1x: 2bits [6]: ttl [7]: uart tx, rx loopback	0x0e
0x98	UART_CTRL2	RW	[3:0] rts trig level [4] rts Parity [5] rts manual value [6] rts manual enable [7] rts enable	0xa5
0x99	UART_CTRL3	RW	[3:0]: rx_irq_trig level [7:4] tx_irq_trig level	0x44
0x9a	UART_RXTIMEOUT_O_L	RW	[7:0]: R_rxtimeout_o[7:0] The setting is transfer one bytes need cycles base on uart_clk. For example, if transfer one bytes (1 start bit+8bits	0xc0

Address	Name	R/W	Description	Reset Value
			data+1 priority bit+2 stop bits) total 12 bits, this register setting should be (bwpc+1)*12.	
0x9b	UART_RXTIMEOUT_O_H	RW	[1:0]: R_rxtimeout_o[9:8] 2'b00:rx timeout time is r_rxtimeout[7:0] 2'b01:rx timeout time is r_rxtimeout[7:0]*2 2'b10:rx timeout time is r_rxtimeout[7:0]*3 3'b11: rx timeout time is r_rxtimeout[7:0]*4 R_rxtimeout is for rx dma to decide the end of each transaction. Supposed the interval between each byte in one transaction is very short. [5]: rsvd (p7816_en_o) [6]: mask_txdone [7]: mask_err	0x01
0x9c	UART_BUFCNT	R	[3:0]: rx_buf_cnt [7:4]: tx_buf_cnt	0x00
0x9d	UART_STATUS	R	[2:0] rbcnt [3] irq_o [6:4]wbcnt [6] write 1 to clear rx [7] rx_err, write 1 to clear tx	0x00
0x9e	UART_TXRX_STATUS	R	[0] txdone [1] tx_buf_irq [2] rxdone [3] rx_buf_irq	0x00
0x9f	UART_STATE	R	[2:0] tstate_i [7:4] rstate_i	0x00

Addresses 0x90~0x93 serve to write data into TX buffer or read data from RX buffer.

Addresses 0x94~0x95 serve to configure UART clock.

Address 0x96 serves to set baud rate (bit[3:0]), enable RX/TX DMA mode (bit[4:5]), and enable RX/TX interrupt (bit[6:7]).

Address 0x97 mainly serves to configure CTS. Bit[1] should be set to 1b'1 to enable CTS. Bit[0] serves to configure CTS signal level. Bit[2:3] serve to enable parity bit and select even/odd parity. Bit[5:4] serve to select 1/1.5/2 bits for stop bit. Bit[6] serves to configure whether RX/TX level should be inverted.

Address 0x98 serves to configure RTS. Bit[7] and Bit[3:0] serve to enable RTS and configure RTS signal level.

Address 0x99 serves to configure the number of bytes in RX/TX buffer to trigger interrupt.

The number of bytes in RX/TX buffer can be read from address 0x9c.

## 8 PWM

The TLSR8250F512 supports 6-channel PWM (Pulse-Width-Modulation) output. Each PWM#n (n=0~5) has its corresponding inverted output at PWM#n\_N pin.

### 8.1 Register table

Table 8- 1 Register table for PWM

Address	Mnemonic	Type	Description	Reset Value
0x780	PWM_EN	R/W	[1]: 0--disable PWM1, 1--enable PWM1 [2]: 0--disable PWM2, 1--enable PWM2 [3]: 0--disable PWM3, 1--enable PWM3 [4]: 0--disable PWM4, 1--enable PWM4 [5]: 0--disable PWM5, 1--enable PWM5	0x00
0x781	PWM_ENO	R/W	[0]: 0--disable PWM0, 1--enable PWM0	0x00
0x782	PWM_CLKDIV	R/W	Set PWM_clk: (PWM_CLKDIV+1)*sys_clk	0x00
0x783	PWM_MODE	R/W	[3:0]: PWM0 mode select 0000-pwm0 normal mode 0001-pwm0 count mode 0011-pwm0 IR mode 0111-pwm0 IR FIFO mode 1111-pwm0 IR DMA FIFO mode	0x00
0x784	PWM_CC0	R/W	[5:0]:1'b1 invert PWM output	0x00
0x785	PWM_CC1	R/W	[5:0]:1'b1 invert PWM_INV output	0x00
0x786	PWM_CC2	R/W	[5:0]: Signal frame polarity of PWM5~PWM0 1b'0-high level first 1b'1-low level first	0x00
0x788~ 0x793	reserved			
0x794	PWM_TCMPO	R/W	[7:0] bits 7-0 of PWM0's high time or low time(if pola[0]=1)	0x00
0x795	PWM_TCMPO	R/W	[15:8] bits 15-8 of PWM0's high time or low time	0x00
0x796	PWM_TMAX0	R/W	[7:0] bits 7-0 of PWM0's cycle time	0x00
0x797	PWM_TMAX0	R/W	[15:8] bits 15-8 of PWM0's cycle time	0x00
0x798	PWM_TCMP1	R/W	[7:0] bits 7-0 of PWM1's high time or	0x00

Address	Mnemonic	Type	Description	Reset Value
			low time(if pola[1]=1)	
0x799	PWM_TCMP1	R/W	[15:8] bits 15-8 of PWM1's high time or low time	0x00
0x79a	PWM_TMAX1	R/W	[7:0] bits 7-0 of PWM1's cycle time	0x00
0x79b	PWM_TMAX1	R/W	[15:8] bits 15-8 of PWM1's cycle time	0x00
0x79c	PWM_TCMP2	R/W	[7:0] bits 7-0 of PWM2's high time or low time(if pola[2]=1)	0x00
0x79d	PWM_TCMP2	R/W	[15:8] bits 15-8 of PWM2's high time or low time	0x00
0x79e	PWM_TMAX2	R/W	[7:0] bits 7-0 of PWM2's cycle time	0x00
0x79f	PWM_TMAX2	R/W	[15:8] bits 15-8 of PWM2's cycle time	0x00
0x7a0	PWM_TCMP3	R/W	[7:0] bits 7-0 of PWM3's high time or low time(if pola[3]=1)	0x00
0x7a1	PWM_TCMP3	R/W	[15:8] bits 15-8 of PWM3's high time or low time	0x00
0x7a2	PWM_TMAX3	R/W	[7:0] bits 7-0 of PWM3's cycle time	0x00
0x7a3	PWM_TMAX3	R/W	[15:8] bits 15-8 of PWM3's cycle time	0x00
0x7a4	PWM_TCMP4	R/W	[7:0] bits 7-0 of PWM4's high time or low time(if pola[4]=1)	0x00
0x7a5	PWM_TCMP4	R/W	[15:8] bits 15-8 of PWM4's high time or low time	0x00
0x7a6	PWM_TMAX4	R/W	[7:0] bits 7-0 of PWM4's cycle time	0x00
0x7a7	PWM_TMAX4		[15:8] bits 15-8 of PWM4's cycle time	0x00
0x7a8	PWM_TCMP5	R/W	[7:0] bits 7-0 of PWM5's high time or low time(if pola[5]=1)	0x00
0x7a9	PWM_TCMP5	R/W	[15:8] bits 15-8 of PWM5's high time or low time	0x00
0x7aa	PWM_TMAX5	R/W	[7:0] bits 7-0 of PWM5's cycle time	0x00
0x7ab	PWM_TMAX5	R/W	[15:8] bits 15-8 of PWM5's cycle time	0x00
0x7ac	PWM_PNUM0	R/W	[7:0]PWM0 Pulse number in count mode and IR mode	0x00
0x7ad	PWM_PNUM0	R/W	[13:8]	0x00
0x7ae~ 0x7af	reserved			
0x7b0	PWM_MASK0	R/W	INT mask [0] PWM0 Pnum int 0: disable 1: Enable [1] PWM0 ir dma fifo mode int 0: disable 1: Enable [2] PWM0 frame int	0x00



Address	Mnemonic	Type	Description	Reset Value
			0: disable 1: Enable [3] PWM1 frame int 0: disable 1: Enable [4] PWM2 frame int 0: disable 1: Enable [5] PWM3 frame int 0: disable 1: Enable [6] PWM4 frame int 0: disable 1: Enable [7] PWM5 frame int 0: disable 1: Enable	
0x7b1	PWM_INT0	R/W	INT status, write 1 to clear [0]: PWM0 pnum int (have sent PNUM pulses, PWM_NCNT==PWM_PNUM) [1]: PWM0 ir dma fifo mode int (pnum int & fifo empty in ir dma fifo mode) [2]: PWM0 cycle done int (PWM_CNT==PWM_TMAX) [3]: PWM1 cycle done int (PWM_CNT==PWM_TMAX) [4]: PWM2 cycle done int (PWM_CNT==PWM_TMAX) [5]: PWM3 cycle done int (PWM_CNT==PWM_TMAX) [6]: PWM4 cycle done int (PWM_CNT==PWM_TMAX) [7]: PWM5 cycle done int (PWM_CNT==PWM_TMAX)	0x00
0x7b2	PWM_MASK1	R/W	[0]: PWM0 fifo mode fifo cnt int mask 0: disable, 1: Enable	0x00
0x7b3	PWM_INT1	R/W	INT status, write 1 to clear [0]: fifo mode cnt int, when FIFO_NUM (0x7cd[3:0]) is less than FIFO_NUM_LVL (0x7cc[3:0])	0x00
0x7b4	PWM_CNT0	R	[7:0] PWM0 cnt value	
0x7b5	PWM_CNT0		[15:8] PWM0 cnt value	
0x7b6	PWM_CNT1	R	[7:0] PWM1 cnt value	
0x7b7	PWM_CNT1		[15:8] PWM1 cnt value	
0x7b8	PWM_CNT2	R	[7:0] PWM2 cnt value	
0x7b9	PWM_CNT2		[15:8] PWM2 cnt value	
0x7ba	PWM_CNT3	R	[7:0] PWM3 cnt value	
0x7bb	PWM_CNT3		[15:8] PWM3 cnt value	
0x7bc	PWM_CNT4	R	[7:0] PWM4 cnt value	

Address	Mnemonic	Type	Description	Reset Value
0x7bd	PWM_CNT4		[15:8]PWM4 cnt value	
0x7be	PWM_CNT5	R	[7:0]PWM5 cnt value	
0x7bf	PWM_CNT5		[15:8]PWM5 cnt value	
0x7c0	PWM_NCNT0	R	[7:0]PWM0 pluse_cnt value	
0x7c1	PWM_NCNT0		[15:8]PWM0 pluse_cnt value	
0x7c2 ~ 0x7c3	reserved			
0x7c4	PWM_TCMPO_SHADOW	R/W	[7:0] bits 7-0 of PWM0's high time or low time(if pola[0]=1),if shadow bit(fifo data[14]) is 1'b1 in ir fifo mode or dma fifo mode	0x55
0x7c5	PWM_TCMPO_SHADOW	R/W	[15:8] bits 15-8 of PWM0's high time or low time ,if shadow bit(fifo data[14]) is 1'b1 in ir fifo mode or dma fifo mode	0x55
0x7c6	PWM_TMAX0_SHADOW	R/W	[7:0] bits 7-0 of PWM0's cycle time, if shadow bit(fifo data[14]) is 1'b1 in ir fifo mode or dma fifo mode	0x00
0x7c7	PWM_TMAX0_SHADOW	R/W	[15:8] bits 15-8 of PWM0's cycle time, if shadow bit(fifo frame[14]) is 1'b1 in ir fifo mode or dma fifo mode	0x00
0x7c8	FIFO_DAT0_ENTRY	R/W	Use in ir fifo mode	
0x7c9	FIFO_DAT1_ENTRY	R/W	Use in ir fifo mode	
0x7ca	FIFO_DAT2_ENTRY	R/W	Use in ir fifo mode	
0x7cb	FIFO_DAT3_ENTRY	R/W	Use in ir fifo mode	
0x7cc	FIFO_NUM_LVL	R/W	FIFO num int trigger level	0x00
0x7cd	FIFO_SR	R	[3:0]: FIFO DATA NUM(byte) [4]: FIFO EMPTY [5]: FIFO FULL	
0x7ce	FIFO_CLR	W1	[0]: write 1 to clear data in FIFO	0x00

## 8.2 Enable PWM

Register PWM\_EN (address 0x780)[5:1] and PWM\_EN0 (address 0x781)[0] serves to enable PWM5~PWM0 respectively via writing "1" for the corresponding bits.

## 8.3 Set PWM clock

PWM clock derives from system clock. Register PWM\_CLKDIV (address 0x782) serves to set the frequency dividing factor for PWM clock. Formula below applies:

$$F_{PWM} = F_{System\ clock} / (PWM\_CLKDIV + 1)$$

### 8.4 PWM waveform, polarity and output inversion

Each PWM channel has independent counter and 2 status including “Count” and “Remaining”. Count and Remaining status form a signal frame.

#### 8.4.1 Waveform of signal frame

When PWM#n is enabled, first PWM#n enters Count status and outputs High level signal by default. When PWM#n counter reaches cycles set in register PWM\_TCMP#n (address 0x794~0x795, 0x798~0x799, 0x79c~0x79d, 0x7a0~0x7a1, 0x7a4~0x7a5, 0x7a8~0x7a9) / PWM\_TCMP0\_SHADOW (0x7c4~0x7c5), PWM#n enters Remaining status and outputs Low level till PWM#n cycle time configured in register PWM\_TMAX#n (address 0x796~0x797, 0x79a~0x79b, 0x79e~0x79f, 0x7a2~0x7a3, 0x7a6~0x7a7, 0x7aa~0x7ab) / PWM\_TMAX0\_SHADOW (0x7c6~0x7c7) expires.

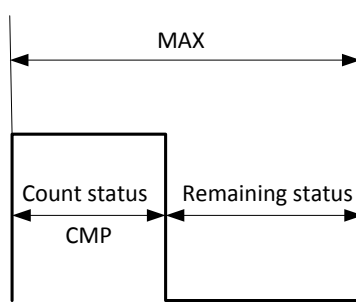

Figure 8- 1 A signal frame

An interruption will be generated at the end of each signal frame if enabled via register PWM\_MASK (address 0x7b0[2:7]).

#### 8.4.2 Invert PWM output

PWM#n and PWM#n\_N output could be inverted independently via register PWM\_CC0 (address 0x784) and PWM\_CC1 (address 0x785). When the inversion bit is enabled, waveform of the corresponding PWM channel will be inverted completely.

#### 8.4.3 Polarity for signal frame

By default, PWM#n outputs High level at Count status and Low level at Remaining status. When the corresponding polarity bit is enabled via register PWM\_CC2 (address 0x786[5:0]), PWM#n will output Low level at Count status and High level at Remaining status.

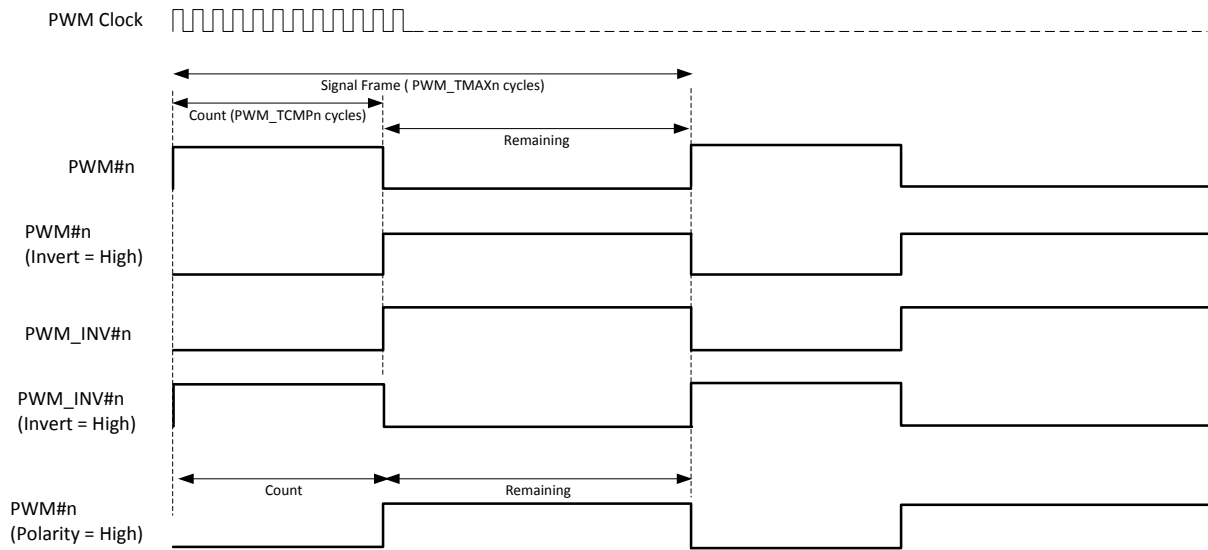

Figure 8-2 PWM output waveform chart

## 8.5 PWM mode

### 8.5.1 Select PWM mode

PWM0 supports five modes, including Continuous mode (normal mode, default), Counting mode, IR mode, IR FIFO mode, IR DMA FIFO mode.

PWM1~PWM5 only support Continuous mode.

Register PWM\_MODE (address 0x783) serves to select PWM0 mode.

### 8.5.2 Continuous mode

PWM0~PWM5 all support Continuous mode. In this mode, PWM#n continuously sends out signal frames. PWM#n should be disabled via address 0x780/0x781 to stop it; when stopped, the PWM output will turn low immediately.

During Continuous mode, waveform could be changed freely via PWM\_TCMp#n and PWM\_TMAX#n. New configuration for PWM\_TCMp#n and PWM\_TMAX#n will take effect in the next signal frame.

After each signal frame is finished, corresponding PWM cycle done interrupt flag bit (0x7b1[2:7]) will be automatically set to 1b'1. If the interrupt is enabled by setting PWM\_MASK0 (address 0x7b0[2:7]) as 1b'1, a frame interruption will be generated. User needs to write 1b'1 to the flag bit to manually clear it.

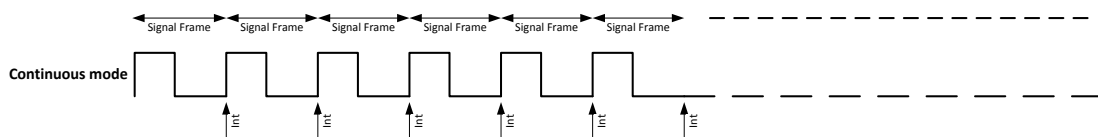

Figure 8-3 Continuous mode

### 8.5.3 Counting mode

Only PWM0 supports Counting mode. Address 0x783[3:0] should be set as 4b'0001 to select PWM0 counting mode.

In this mode, PWM0 sends out specified number of signal frames which is defined as a pulse group. The number is configured via register PWM\_PNUM0 (address 0x7ac~0x7ad).

After each signal frame is finished, PWM0 cycle done interrupt flag bit (0x7b1[2]) will be automatically set to 1b'1. If the interrupt is enabled by setting PWM\_MASK0 (address 0x7b0[2]) as 1b'1, a frame interruption will be generated. User needs to write 1b'1 to the flag bit to manually clear it.

After a pulse group is finished, PWM0 will be disabled automatically, and PWM0 pnum interrupt flag bit (0x7b1[0]) will be automatically set to 1b'1. If the interrupt is enabled by setting PWM\_MASK0 (address 0x7b0[0]) as 1b'1, a Pnum interruption will be generated. User needs to write 1b'1 to the flag bit to manually clear it.

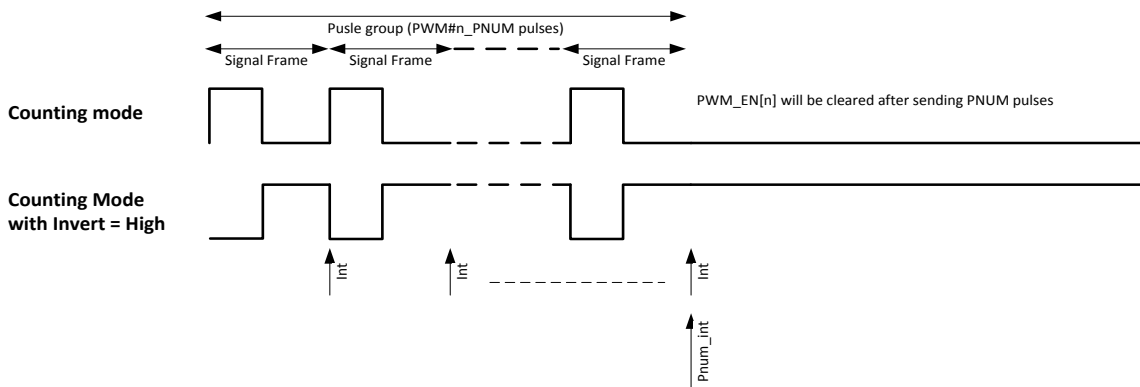

Figure 8-4 Counting mode (n=0)

Counting mode also serves to stop IR mode gracefully. Refer to **section 8.5.4** for details.

### 8.5.4 IR mode

Only PWM0 supports IR mode. Address 0x783[3:0] should be set as 4b'0011 to select PWM0 IR mode.

In this mode, specified number of frames is defined as one pulse group. In contrast to Counting mode where PWM0 stops after first pulse group is finished, PWM0 will constantly send pulse groups in IR mode.

During IR mode, PWM0 output waveform could also be changed freely via WM\_TCMPO, PWM\_TMAX0 and PWM\_PNUM0. New configuration for PWM\_TCMPO, PWM\_TMAX0 and PWM\_PNUM0 will take effect in the next pulse group.

To stop IR mode and complete current pulse group, user can switch PWM0 from IR mode to Counting mode so that PWM0 will stop after current pulse group is finished. If PWM0 is disabled

directly via PWM\_EN0 (0x781[0]), PWM0 output will turn Low immediately despite of current pulse group.

After each signal frame/pulse group is finished, PWM0 cycle done interrupt flag bit (0x7b1[2])/PWM0 pnum interrupt flag bit (0x7b1[0]) will be automatically set to 1b'1. A frame interruption/Pnum interruption will be generated (if enabled by setting address 0x7b0[2]/0x7b0[0] as 1b'1).

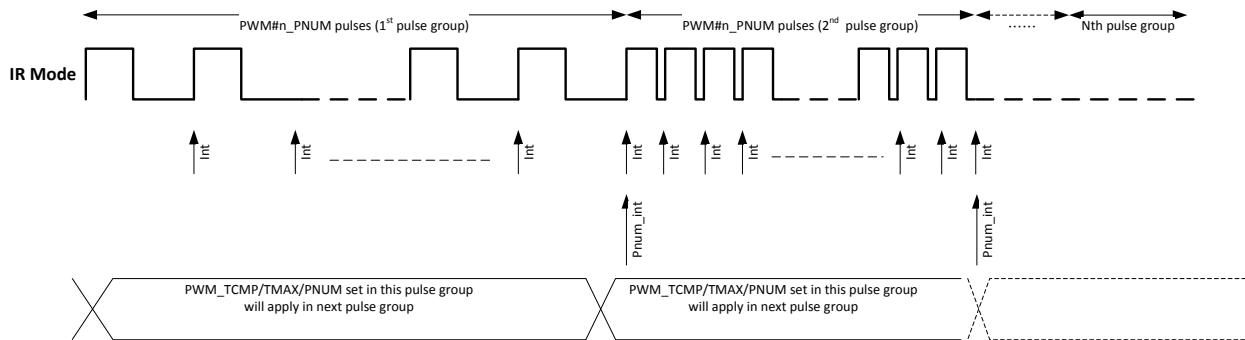

Figure 8-5 IR mode (n=0)

### 8.5.5 IR FIFO mode

IR FIFO mode is designed to allow IR transmission of long code patterns without the continued intervention of MCU, and it is designed as a selectable working mode on PWM0. The IR carrier frequency is divided down from the system clock and can be configured as any normal IR frequencies, e.g. 36kHz, 38kHz, 40kHz, or 56kHz.

Only PWM0 supports IR FIFO mode. Address 0x783[3:0] should be set as 4b'0111 to select PWM0 IR FIFO mode.

An element (“FIFO CFG Data”) is defined as basic unit of IR waveform, and written into FIFO. This element consists of 16 bits, including:

- ✧ bit[13:0] defines PWM pulse number of current group.
- ✧ bit[14] determines duty cycle and period for current PWM pulse group.
  - 0: use configuration of TCMP0 and TMAX0 in 0x794~0x797;
  - 1: use configuration of TCMP0\_SHADOW and TMAX0\_SHADOW in 0x7c4~0x7c7.
- ✧ bit[15] determines whether current PWM pulse group is used as carrier, i.e. whether PWM will output pulse (1) or low level (0).

User should use FIFO\_DATA\_ENTRY in 0x7c8~0x7cb to write the 16-bit “FIFO CFG Data” into FIFO by byte or half word or word.

- ✧ To write by byte, user should successively write 0x7c8, 0x7c9, 0x7ca and 0x7cb.
- ✧ To write by half word, user should successively write 0x7c8 and 0x7ca.
- ✧ To write by word, user should write 0x7c8.

FIFO depth is 8 bytes. User can read the register FIFO\_SR in 0x7cd to view FIFO empty/full

status and check FIFO data number.

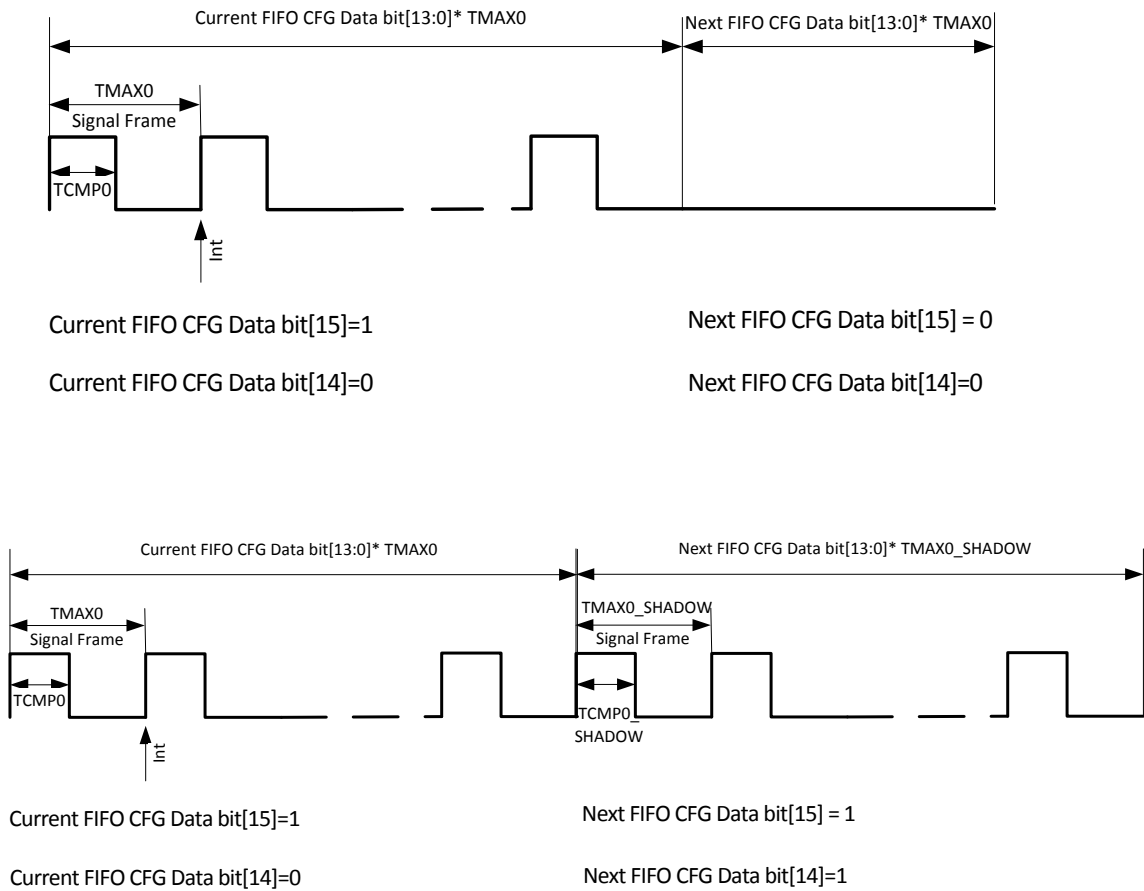

Figure 8- 6 IR format examples

When “FIFO CFG Data” is configured in FIFO and PWM0 is enabled via PWM\_EN0 (address 0x781[0]), the configured waveforms will be output from PWM0 in sequence. As long as FIFO doesn’t overflow, user can continue to add waveforms during IR waveforms sending process, and long IR code that exceeds the FIFO depth can be implemented this way. After all waveforms are sent, FIFO becomes empty, PWM0 will be disabled automatically.

The FIFO\_CLR register (address 0x7ce[0]) serves to clear data in FIFO. Writing 1b’1 to this register will clear all data in the FIFO. Note that the FIFO can only be cleared when not in active transmission.

### 8.5.6 IR DMA FIFO mode

IR DMA FIFO mode is designed to allow IR transmission of long code patterns without occupation of MCU, and it is designed as a selectable working mode on PWM0. The IR carrier frequency is divided down from the system clock and can be configured as any normal IR frequencies, e.g. 36kHz, 38kHz, 40kHz, or 56kHz.

Only PWM0 supports IR DMA FIFO mode. Address 0x783[3:0] should be set as 4b'1111 to select PWM0 IR DMA FIFO mode.

This mode is similar to IR FIFO mode, except that “FIFO CFG Data” is written into FIFO by DMA instead of MCU. User should write the configuration of “FIFO CFG Data” into RAM, and then enable DMA channel 5. DMA will automatically write the configuration into FIFO.

**\*Note:** In this mode, when DMA channel 5 is enabled, PWM will automatically output configured waveform, without the need to manually enable PWM0 via 0x781[0] (i.e. 0x781[0] will be set as 1b'1 automatically).

### Example 1:

**Suppose** Mark carrier (pulse) frequency1(F1) = 40kHz, duty cycle 1/3

Mark carrier (pulse) frequency2(F2) = 50kHz, duty cycle 1/2

Space carrier (low level) frequency(F3) = 40kHz

If user wants to make PWM send waveforms in following format (PWM CLK =24MHz):

Burst(20[F1]), i.e. 20 F1 pulses

Burst(30[F2]),

Burst(50[F1]) ,

Burst(50[F2]),

Burst(20[F1],10[F3]),

Burst(30[F2],10[F3])

**Step1:** Set carrier F1 frequency as 40kHz, set duty cycle as 1/3.

Set **PWM\_TMAX0** as 0x258 (i.e. 24MHz/40kHz=600=0x258).

Since duty cycle is 1/3, set **PWM\_TCMPO** as 0xc8 (i.e. 600/3=200=0xc8).

Set carrier F2 frequency as 50kHz, set duty cycle as 1/2.

Set **PWM\_TMAX0\_SHADOW** as 0x1e0 (i.e. 24MHz/50kHz=480=0x1e0).

Since duty cycle is 1/2, set **PWM\_TCMPO\_SHADOW** as 0xf0 (i.e. 480/2=240=0xf0).

**Step2:** Generate “FIFO CFG Data” sequence.

Burst(20[F1]): {[15]: 1'b1, [14]: 1'b0, [13:0]: 'd20}=0x8014.

Burst(30[F2]): {[15]: 1'b1, [14]: 1'b1, [13:0]: 'd30}=0xc01e.

Burst(50[F1]) : {[15]: 1'b1, [14]: 1'b0, [13:0]: 'd50}=0x8032.

Burst(50[F2]): {[15]: 1'b1, [14]: 1'b1, [13:0]: 'd50}=0xc032.

Burst(20[F1],10[F3]): {[15]: 1'b1, [14]: 1'b0, [13:0]: 'd20}=0x8014,

{[15]: 1'b0, [14]: 1'b0, [13:0]: 'd10}=0x000a.



Burst(30[F2],10[F3]): {[15]: 1'b1, [14]: 1'b1, [13:0]: 'd30}=0xc01e,  
 {[15]:1'b0, [14]: 1'b0, [13:0]: 'd10}=0x000a.

**Step3:** Write "FIFO CFG Data" into SRAM in DMA format.

DMA SOURCE ADDRESS+0x00: 0x0000\_0010 (dma transfer-length: 16byte)

DMA SOURCE ADDRESS+0x04: 0xc01e\_8014 (LITTLE ENDIAN)

DMA SOURCE ADDRESS+0x08: 0xc032\_8032

DMA SOURCE ADDRESS+0x0c: 0x000a\_8014

DMA SOURCE ADDRESS+0x10: 0x000a\_c01e

**Step4:** Enable DMA channel 5 to send PWM waveforms.

Write 1'b1 to address 0x524[5] to enable DMA channel 5.

After all waveforms are sent, FIFO becomes empty, PWM0 will be disabled automatically (address 0x781[0] is automatically cleared). The FIFO mode stop interrupt flag bit (address 0x7b3[0]) will be automatically set as 1b'1. If the interrupt is enabled by setting PWM\_MASK1 (address 0x7b2[0]) as 1b'1, a FIFO mode stop interrupt will be generated. User needs to write 1b'1 to the flag bit to manually clear it.

#### Example 2:

**Suppose** carrier frequency is 38kHz, system clock frequency is 24MHz, duty cycle is 1/3, and the format of IR code to be sent is shown as below:

- 1) Preamble waveform: 9ms carrier + 4.5ms low level.
- 2) Data 1 waveform: 0.56ms carrier + 0.56ms low level.
- 3) Data 0 waveform: 0.56ms carrier + 1.69ms low level.
- 4) Repeat waveform: 9ms carrier + 2.25ms low level + 0.56ms carrier. Repeat waveform duration is 11.81ms, interval between two adjacent repeat waveforms is 108ms.
- 5) End waveform: 0.56ms carrier.

User can follow the steps below to configure related registers:

**Step1:** Set carrier frequency as 38kHz, set duty cycle as 1/3.

Set **PWM\_TMAX0** as 0x277 (i.e.  $24\text{MHz}/38\text{kHz}=631=0x277$ ).

Since duty cycle is 1/3, set **PWM\_TCMPO** as 0xd2 (i.e.  $631/3=210=0xd2$ ).

**Step2:** Generate "FIFO CFG Data" sequence.

**Preamble waveform:**

9ms carrier: {[15]:1'b1, [14]:1'b0, [13:0]: 9\*38='d 342=14'h 156}=0x8156

4.5ms low level: {[15]:1'b0, [14]:1'b0, [13:0]: 4.5\*38='d 171=14'h ab}=0x00ab

**Data 1 waveform:**

0.56ms carrier: {[15]:1'b1, [14]:1'b0, [13:0]: 0.56\*38='d 21=14'h 15}=0x8015

0.56ms low level: {[15]:1'b0, [14]:1'b0, [13:0]: 0.56\*38='d 21=14'h 15}=0x0015

**Data 0 waveform:**

0.56ms carrier: {[15]:1'b1, [14]:1'b0, [13:0]: 0.56\*38='d 21=14'h 15}=0x8015

1.69ms low level: {[15]:1'b0, [14]:1'b0, [13:0]: 1.69\*38='d 64=14'h 40}=0x0040

**Repeat waveform:**

9ms carrier: {[15]:1'b1, [14]:1'b0, [13:0]: 9\*38='d 342=14'h 156}=0x8156

2.25ms low level: {[15]:1'b0, [14]:1'b0, [13:0]: 2.25\*38='d 86=14'h 56}=0x0056

0.56ms carrier: {[15]:1'b1, [14]:1'b0, [13:0]: 0.56\*38='d 21=14'h 15}=0x8015

108ms -11.81ms =96.19ms low level:

{[15]:1'b0, [14]:1'b0, [13:0]: 96.19\*38='d 3655=14'h e47}=0x0e47

**End waveform:**

0.56ms carrier: {[15]:1'b1, [14]:1'b0, [13:0]: 0.56\*38='d 21=14'h 15}=0x8015

**Step3:** Write "IR CFG Data" into SRAM in DMA format.

If user want PWM0 to send IR waveform in following format:

Preamble+0x5a+Repeat+End

Preamble: 0x8156, 0x00ab

0x5a=8'b01011010

Data 0: 0x8015, 0x0040

Data 1: 0x8015, 0x0015

Data 0: 0x8015, 0x0040

Data 1: 0x8015, 0x0015

Data 1: 0x8015, 0x0015

Data 0: 0x8015, 0x0040

Data 1: 0x8015, 0x0015

Data 0: 0x8015, 0x0040

Repeat: 0x8156, 0x0056, 0x8015, 0x0e47

End: 0x8015.

User needs to write the configuration information above into source address of DMA channel 5, as shown below:

DMA SOURCE ADDRESS+0x00: 0x0000\_002e (dma transfer-length: 46byte)

DMA SOURCE ADDRESS+0x04: 0x00ab\_8156 (Preamble) (LITTLE ENDIAN)  
DMA SOURCE ADDRESS+0x08: 0x0040\_8015 (Data 0)  
DMA SOURCE ADDRESS+0x0c: 0x0015\_8015 (Data 1)  
DMA SOURCE ADDRESS+0x10: 0x0040\_8015 (Data 0)  
DMA SOURCE ADDRESS+0x14: 0x0015\_8015 (Data 1)  
DMA SOURCE ADDRESS+0x18: 0x0015\_8015 (Data 1)  
DMA SOURCE ADDRESS+0x1c: 0x0040\_8015 (Data 0)  
DMA SOURCE ADDRESS+0x20: 0x0015\_8015 (Data 1)  
DMA SOURCE ADDRESS+0x24: 0x0040\_8015 (Data 0)  
DMA SOURCE ADDRESS+0x28: 0x0056\_8156 (Repeat)  
DMA SOURCE ADDRESS+0x2c: 0x0e47\_8015 (Repeat)  
DMA SOURCE ADDRESS+0x30: 0x8015 (End)

**Step4:** Enable DMA channel 5 to send PWM waveforms.

Write 1'b1 to address 0x524[5] to enable DMA channel 5.

After all waveforms are sent, FIFO becomes empty, PWM0 will be disabled automatically (address 0x781[0] is automatically cleared). The FIFO mode stop interrupt flag bit (address 0x7b3[0]) will be automatically set as 1b'1. If the interrupt is enabled by setting PWM\_MASK1 (address 0x7b2[0]) as 1b'1, a FIFO mode stop interrupt will be generated. User needs to write 1b'1 to the flag bit to manually clear it.

## 8.6 PWM interrupt

There are 9 interrupt sources from PWM function.

After each signal frame, PWM#n (n=0~5) will generate a frame-done IRQ (Interrupt Request) signal.

In Counting mode and IR mode, PWM0 will generate a Pnum IRQ signal after completing a pulse group.

In IR FIFO mode, PWM0 will generate a FIFO mode count IRQ signal when the FIFO\_NUM value is less than the FIFO\_NUM\_LVL, and will generate a FIFO mode stop IRQ signal after FIFO becomes empty.

In IR DMA FIFO mode, PWM0 will generate an IR waveform send done IRQ signal, after DMA has sent all configuration data, FIFO becomes empty and final waveform is sent.

To enable PWM interrupt, the total enabling bit "irq\_pwm" (address 0x641[6], see **section 6 Interrupt**) should be set as 1b'1. To enable various PWM interrupt sources, PWM\_MASK0 (address 0x7b0[7:0]) and PWM\_MASK1 (address 0x7b2[0]) should be set as 1b'1 correspondingly.

Interrupt status can be cleared via register PWM\_INT0 (address 0x7b1[7:0]) and PWM\_INT1 (address 0x7b3[0]).

## 9 SAR ADC

The TLSR8250F512 integrates one SAR ADC module, which can be used to sample analog input signals such as battery voltage, temperature sensor, as well as internal noise signal.

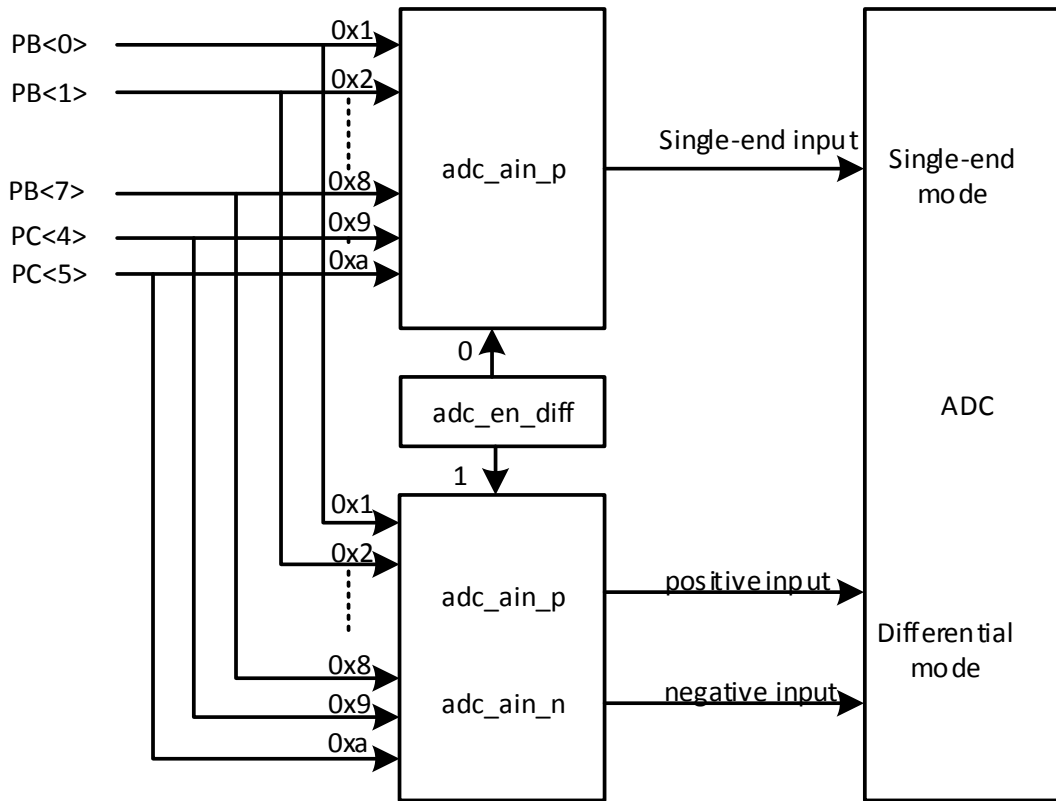

Figure 9- 1 Block diagram of ADC

### 9.1 Power on/down

The SAR ADC is disabled by default. To power on the ADC, the analog register `adc_pd` (`afe_0xfc<5>`) should be set as `1b'0`.

### 9.2 ADC clock

ADC clock is derived from external 24MHz crystal source, with frequency dividing factor configurable via the analog register `adc_clk_div` (`afe_0xf4<2:0>`).

$$\text{ADC clock frequency (marked as } F_{\text{ADC\_clk}}) = 24\text{MHz}/(\text{adc\_clk\_div}+1)$$

### 9.3 ADC control in auto mode

#### 9.3.1 Set max state and enable channel

The SAR ADC supports up to four channels including RNG channel, left channel, right channel and Misc channel. The RNG channel only contains one “Capture” state (state 0), while the left, right and Misc channels all consist of one “Set” state and one “Capture” state.

- ✧ The analog register `r_max_scnt` (`afe_0xf2<6:4>`) serves to set the max state index. As shown in the example below, the `r_max_scnt` should be set as `0x06`.

0	1	2	3	4	5	6
Capture	Set	Capture	Set	Capture	Set	Capture

- ✧ The RNG/left/Misc channel can be enabled independently via `r_en_rns` (`afe_0xf2<3>`), `r_en_left` (`afe_0xf2<0>`), `r_en_misc` (`afe_0xf2<2>`).
- ✧ Only when the left channel is enabled, can the right channel be enabled via `r_en_right` (`afe_0xf2<1>`).
- ✧ To sample internal noise signals, the RNG channel should be enabled.

#### 9.3.2 “Set” state

The length of “Set” state for left, right and Misc channel is configurable via the analog register `r_max_s` (`afe_0xf1<3:0>`).

$$\text{“Set” state duration (marked as } T_{sd}\text{)} = r\_max\_s / 24\text{MHz.}$$

Each “Set” state serves to set ADC control signals for current channel via corresponding analog registers, including:

- ✧ `adc_en_diff`: `afe_0xec<4>` (left channel), `afe_0xec<5>` (right channel), `afe_0xec<6>` (Misc channel). Select single-end or differential input mode.
- ✧ `adc_ain_p`: `afe_0xe8<7:4>` (Misc channel), `afe_0xe9<7:4>` (left channel), `afe_0xea<7:4>` (right channel). Select single-end input in single-end mode, or select positive input in differential mode.
- ✧ `adc_ain_n`: `afe_0xe8<3:0>` (Misc channel), `afe_0xe9<3:0>` (left channel), `afe_0xea<3:0>` (right channel). Select negative input in differential mode.
- ✧ `adc_vref`: `afe_0xe7<1:0>` (left channel), `afe_0xe7<3:2>` (right channel), `afe_0xe7<5:4>` (Misc channel). Set reference voltage  $V_{REF}$ . ADC maximum input range is the determined by the ADC reference voltage.
- ✧ `adc_sel_ai_scale`: `afe_0xfa<7:6>`. Set scaling factor for ADC analog input as 1 (default), 1/2, 1/4 or 1/8.

By setting this scaling factor, ADC maximum input range can be extended based on the  $V_{REF}$ .

For example, suppose the  $V_{REF}$  is set as 1.2V:

Since the scaling factor is 1 by default, the ADC maximum input range should be 0~1.2V (single mode)/-1.2V~+1.2V (differential mode).

If the scaling factor is set as 1/2, ADC maximum input range should change to 0~2.4V (single mode)/-2.4V~+2.4V (differential mode).

- ✧ `adc_res`: `afe_0xeb<1:0>` (left channel), `afe_0xeb<5:4>` (right channel), `afe_0xec<1:0>` (Misc channel). Set resolution as 8/10/12/14 bits.

ADC data is always 15-bit format no matter what the resolution is set. For example, 14 bits resolution indicates ADC data consists of 14-bit valid data and 1-bit sign extension bit.

- ✧ `adc_tsamp`: `afe_0xed<3:0>` (left channel), `afe_0xed<7:4>` (right channel), `afe_0xee<3:0>` (Misc channel). Set sampling time which determines the speed to stabilize input signals.

$$\text{Sampling time (marked as } T_{\text{samp}}) = \text{adc\_tsamp} / F_{\text{ADC\_clk}}$$

The lower sampling cycle, the shorter ADC convert time.

### 9.3.3 “Capture” state

For the RNG channel, the “Capture” state serves to capture random number sequence (RNS) derived from internal noise.

For the left, right and Misc channels, at the beginning of each “Capture” state, run signal is issued automatically to start an ADC sampling and conversion process; at the end of each “Capture” state, ADC output data is captured.

- ✧ The length of “Capture” state for RNS and Misc channel is configurable via the analog register `r_max_mc[9:0]` (`afe_0xf1<7:6>`, `afe_0xef<7:0>`).

$$\text{“Capture” state duration for RNS \& Misc channel (marked as } T_{\text{cd}}) = r\_max\_mc / 24\text{MHz.}$$

- ✧ The length of “Capture” state for left and right channel is configurable via the analog register `r_max_c[9:0]` (`afe_0xf1<5:4>`, `afe_0xf0<7:0>`).

$$\text{“Capture” state duration for left \& right channel (marked as } T_{\text{cd}}) = r\_max\_c / 24\text{MHz.}$$

- ✧ The RNG channel will output 1bit random number, and user can read the analog register `rng[15:0]` (`afe_0xf6<7:0>` ~ `afe_0xf5<7:0>`) to obtain the 16-bit random number consisting of 1-bit real-time random number output and 15-bit buffered RNS.

- ✧ The “VLD” bit (`afe_0xf8<7>`) will be set as 1b’1 at the end of “Capture” state to indicate the ADC data is valid, and this flag bit will be cleared automatically.

- ✧ The 15-bit ADC output data for Misc channel can be read from the analog register `adc_dat[14:0]` (`afe_0xf8<6:0>`, `afe_0xf7<7:0>`).

Note: The total duration “ $T_{td}$ ”, which is the sum of the length of “Set” state and “Capture” state for all channels available, determines the sampling rate.

$$\text{Sampling frequency (marked as } F_s) = 1 / T_{td}$$

### 9.3.4 Usage cases

#### 9.3.4.1 Case 1: 4-channel sampling for random number, Left, Right and Misc

In this case, the RNG, left, right and Misc channels should be enabled by setting `afe_0xf2<3:0>` as `0xf`, and the max state index should be set as “6” by setting `afe_0xf2<6:4>` as `0x6`.

The total duration (marked as  $T_{td}$ ) =  $(2 * r_{max\_mc} + 3 * r_{max\_s} + 2 * r_{max\_c}) / 24\text{MHz}$ .

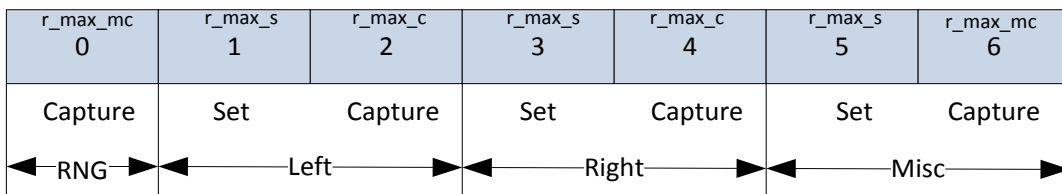

#### 9.3.4.2 Case 2: 3-channel sampling for random number, Left and Misc

In this case, `afe_0xf2<3:0>` should be set as `0xd`, so as to enable the RNG, left and Misc channels and disable the right channel, the max state index should be set as “4” by setting `afe_0xf2<6:4>` as `0x4`.

The total duration (marked as  $T_{td}$ ) =  $(2 * r_{max\_mc} + 2 * r_{max\_s} + 1 * r_{max\_c}) / 24\text{MHz}$ .

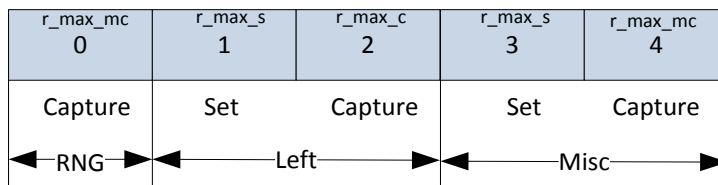

#### 9.3.4.3 Case 3: 3-channel sampling for Left, Right and Misc

In this case, `afe_0xf2<3:0>` should be set as `0x7`, so as to enable the left, right and Misc channels and disable the RNG channel, the max state index should be set as “6” by setting `afe_0xf2<6:4>` as `0x6`.

The total duration (marked as  $T_{td}$ ) =  $(1 * r_{max\_mc} + 3 * r_{max\_s} + 2 * r_{max\_c}) / 24\text{MHz}$ .

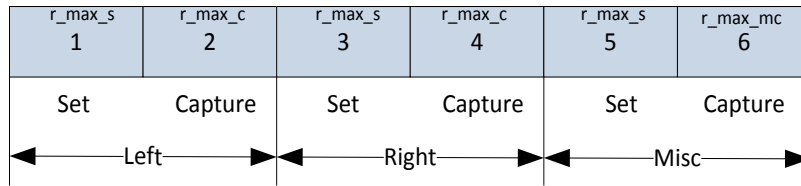

#### 9.3.4.4 Case 4: 3-channel sampling for random number, Left and Right

In this case, `afe_0xf2<3:0>` should be set as 0xB, so as to enable the RNG, left and right channels and disable the Misc channel, the max state index should be set as “4” by setting `afe_0xf2<6:4>` as 0x4.

The total duration (marked as  $T_{td}$ ) =  $(1*r_{max\_mc}+2*r_{max\_s}+2*r_{max\_c}) / 24MHz$ .

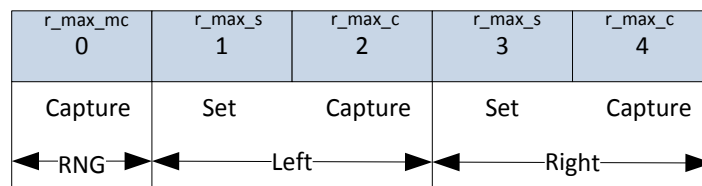

#### 9.3.4.5 Case 5: 2-channel sampling for Left and Misc

In this case, `afe_0xf2<3:0>` should be set as 0x5, so as to enable the left and Misc channels and disable the RNG and right channels, the max state index should be set as “4” by setting `afe_0xf2<6:4>` as 0x4.

The total duration (marked as  $T_{td}$ ) =  $(1*r_{max\_mc}+2*r_{max\_s}+1*r_{max\_c}) / 24MHz$ .

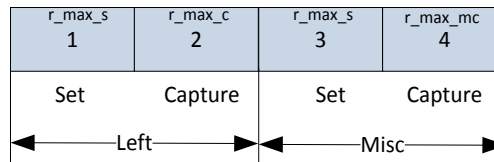

#### 9.3.4.6 Case 6: 2-channel sampling for random number and Left

In this case, `afe_0xf2<3:0>` should be set as 0x9, so as to enable the RNG and left channels and disable the right and Misc channels, the max state index should be set as “2” by setting `afe_0xf2<6:4>` as 0x2.

The total duration (marked as  $T_{td}$ ) =  $(1*r_{max\_mc}+1*r_{max\_s}+1*r_{max\_c}) / 24MHz$ .

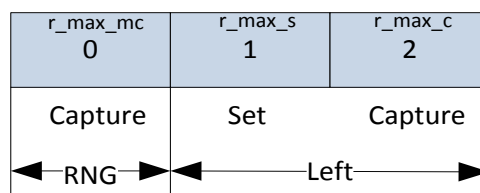



**9.3.4.7 Case 7: 2-channel sampling for random number and Misc**

In this case, `afe_0xf2<3:0>` should be set as `0xC`, so as to enable the RNG and Misc channels and disable the left and right channels, the max state index should be set as “2” by setting `afe_0xf2<6:4>` as `0x2`.

The total duration (marked as  $T_{td}$ ) =  $(2*r_{max\_mc}+1*r_{max\_s}) / 24MHz$ .

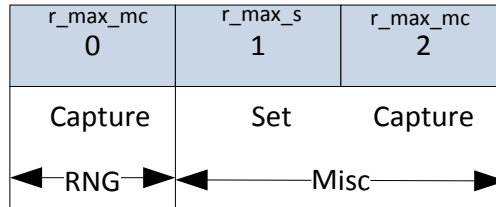

**9.3.4.8 Case 8: 2-channel sampling for Left and Right**

In this case, `afe_0xf2<3:0>` should be set as `0x3`, so as to enable the left and right channels and disable the RNG and Misc channels, the max state index should be set as “4” by setting `afe_0xf2<6:4>` as `0x4`.

The total duration (marked as  $T_{td}$ ) =  $(2*r_{max\_s}+2*r_{max\_c}) / 24MHz$ .

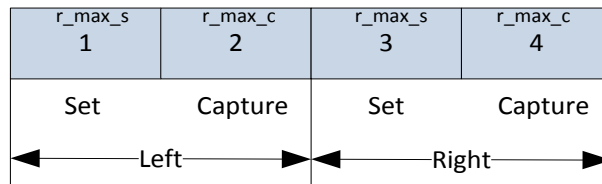

**9.3.4.9 Case 9: 1-channel sampling for Left**

In this case, `afe_0xf2<3:0>` should be set as `0x1`, so as to enable the left channel and disable the RNG, right and Misc channels, the max state index should be set as “2” by setting `afe_0xf2<6:4>` as `0x2`.

The total duration (marked as  $T_{td}$ ) =  $(1*r_{max\_s}+1*r_{max\_c}) / 24MHz$ .

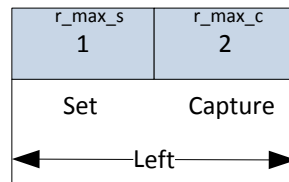

**9.3.4.10 Case 10: 1-channel sampling for Misc**

In this case, `afe_0xf2<3:0>` should be set as `0x4`, so as to enable the Misc channel and disable the RNG, left and right channels, the max state index should be set as “2” by setting `afe_0xf2<6:4>` as `0x2`.

The total duration (marked as  $T_{td}$ ) =  $(1*r_{max\_s}+1*r_{max\_mc}) / 24MHz$ .

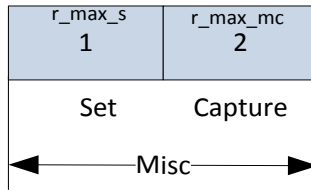

**9.3.4.11 Case 11: 1-channel sampling for RNG**

In this case, afe\_0xf2<3:0> should be set as 0x8, so as to enable the RNG channel and disable the left, right and Misc channels, the max state index should be set as “0” by setting afe\_0xf2<6:4> as 0x0.

The total duration (marked as  $T_{td}$ ) =  $1 * r\_max\_mc / 24MHz$ .

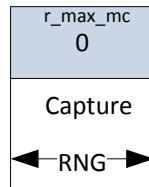

**9.3.4.12 Case 12 with detailed register setting**

This case introduces the register setting details for 3-channel sampling of left, right and Misc channels.

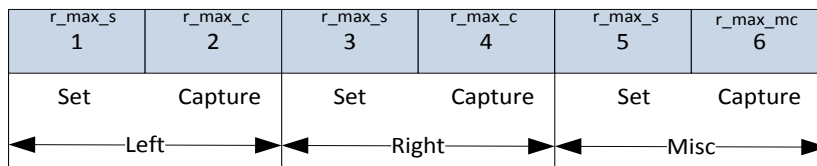

Table 9- 1 Overall register setting

Function	Register setting
Power on the ADC	afe_0xfc<5> = 1b'0
Set $F_{ADC\_clk}$ (ADC clock frequency) as 4MHz	afe_0xf4<2:0> = 5 $F_{ADC\_clk} = 24MHz / (5+1) = 4MHz$
Enable the left, right and Misc channels	afe_0xf2<3:0> = 0x7
Set the max state index as “6”	afe_0xf2<6:4> = 0x6

Table 9- 2 Register setting for L/R/M channel

Function	Register setting		
	Left	Right	Misc
Set $T_{sd}$ ("Set" state duration)	$afe\_0xf1<3:0> = 10$ $T_{sd} = r\_max\_s/24MHz = 10/24MHz = 0.417us$		
Set $T_{cd}$ ("Capture" state duration)	$afe\_0xf1<5:4>=0, afe\_0xf0<7:0>=170$ $T_{cd} = r\_max\_c[9:0]/24MHz = 170/24MHz = 7.1us$		$afe\_0xf1<7:6>=0, afe\_0xef<7:0>=130$ $T_{cd} = r\_max\_mc[9:0]/24MHz = 130/24MHz = 5.4us$
$T_{td}$ (total duration)	$T_{td} = (1*r\_max\_mc+3*r\_max\_s+2*r\_max\_c) / 24MHz = 500/24MHz = 20.83us$		
$F_s$ (Sampling frequency)	$F_s = 1 / T_{td} = 24MHz/500 = 48kHz$		
Set single-end or differential input	$afe\_0xec<4>=1$ differential input	$afe\_0xec<5>=1$ differential input	$afe\_0xec<6>=0$ single-end input
Set input channel	$afe\_0xe9=0x56$ Select B<4> and B<5> as positive input and negative input	$afe\_0xea=0x78$ Select B<6> and B<7> as positive input and negative input	$afe\_0xe8=0x90$ Select C<4> as input
Set reference voltage $V_{REF}$	$afe\_0xe7<1:0>=0$ $V_{REF} = 0.6V$	$afe\_0xe7<3:2>=1$ $V_{REF} = 0.9V$	$afe\_0xe7<5:4>=2$ $V_{REF} = 1.2V$
Set scaling factor for ADC analog input	$afe\_0xfa<7:6>=0$ scaling factor: 1		
	ADC maximum input range: -0.6~+0.6V	ADC maximum input range: -0.9~+0.9V	ADC maximum input range: 0 ~ +1.2V
Set resolution	$afe\_0xeb<1:0>=1$ resolution: 10bits	$afe\_0xeb<5:4>=2$ resolution: 12bits	$afe\_0xec<1:0>=3$ resolution: 14bits
Set $T_{samp}$ (determines the speed to stabilize input before sampling)	$afe\_0xed<3:0>=1$ $T_{samp} = adc\_tsamp / F_{ADC\_clk} = 6/4MHz=1.5us$	$afe\_0xed<7:4>=2$ $T_{samp} = adc\_tsamp / F_{ADC\_clk} = 9/4MHz=2.25us$	$afe\_0xee<3:0>=3$ $T_{samp} = adc\_tsamp / F_{ADC\_clk} = 12/4MHz=3us$

## 9.4 Register table

Table 9- 3 Register table related to SAR ADC

Address Decimal	Mnemonic	Default value	Description
afe_0xe7<1:0>	adc_vrefl	00	Select V <sub>REF</sub> for left channel 0x0: 0.6V 0x1: 0.9V 0x2: 1.2V 0x3: VBAT/N (N=2/3/4, when afe_0xf9<3:2> is set as 0x3/0x2/0x1).
afe_0xe7<3:2>	adc_vrefr	00	Select V <sub>REF</sub> for right channel 0x0: 0.6V 0x1: 0.9V 0x2: 1.2V 0x3: VBAT/N (N=2/3/4, when afe_0xf9<3:2> is set as 0x3/0x2/0x1)
afe_0xe7<5:4>	adc_vrefm	00	Select V <sub>REF</sub> for Misc channel 0x0: 0.6V 0x1: 0.9V 0x2: 1.2V 0x3: VBAT/N (N=2/3/4, when afe_0xf9<3:2> is set as 0x3/0x2/0x1)
afe_0xe7<7:6>	RSVD		
afe_0xe8<3:0>	adc_ain_m_n	0000	Select negative input for Misc channel: 0x0: No input 0x1: B<0> (TSSOP16) 0x2: B<1> (QFN32 & TSSOP16) 0x3: RSVD (B<2>) 0x4: RSVD (B<3>) 0x5: B<4> (QFN32) 0x6: B<5> (QFN32) 0x7: B<6> (QFN32) 0x8: B<7> (QFN32) 0x9: C<4> (QFN32) 0xa: C<5> (TSSOP16) 0xb: RSVD (pga_n<0> (PGA left-channel negative output)) 0xc: RSVD (pga_n<1> (PGA right-channel negative output)) 0xd: tempsensor_n (Temperature sensor negative output) 0xe: Ground 0xf: Ground

Address Decimal	Mnemonic	Default value	Description
afe_0xe8<7:4>	adc_ain_m_p	0000	Select positive input for Misc channel: 0x0: No input 0x1: B<0> (TSSOP16) 0x2: B<1> (QFN32 & TSSOP16) 0x3: RSVD (B<2>) 0x4: RSVD (B<3>) 0x5: B<4> (QFN32) 0x6: B<5> (QFN32) 0x7: B<6> (QFN32) 0x8: B<7> (QFN32) 0x9: C<4> (QFN32) 0xa: C<5> (TSSOP16) 0xb: RSVD (pga_p<0> (PGA left-channel positive output)) 0xc: RSVD (pga_p<1> (PGA right-channel positive output)) 0xd: tempsensor_p (Temperature sensor positive output) 0xe: rsvd 0xf: Vbat (Battery voltage)
afe_0xe9<3:0>	adc_ain_l_n	00	Select negative input for left channel 0x0: No input 0x1: B<0> (TSSOP16) 0x2: B<1> (QFN32 & TSSOP16) 0x3: RSVD (B<2>) 0x4: RSVD (B<3>) 0x5: B<4> (QFN32) 0x6: B<5> (QFN32) 0x7: B<6> (QFN32) 0x8: B<7> (QFN32) 0x9: C<4> (QFN32) 0xa: C<5> (TSSOP16) 0xb: RSVD (pga_n<0> (PGA left-channel negative output)) 0xc: RSVD (pga_n<1> (PGA right-channel negative output)) 0xd: tempsensor_n (Temperature sensor negative output) 0xe: Ground 0xf: Ground
afe_0xe9<7:4>	adc_ain_l_p	00	Select positive input for left channel: 0x0: No input 0x1: B<0> (TSSOP16) 0x2: B<1> (QFN32 & TSSOP16) 0x3: RSVD (B<2>) 0x4: RSVD (B<3>) 0x5: B<4> (QFN32)

Address Decimal	Mnemonic	Default value	Description
			0x6: B<5> (QFN32) 0x7: B<6> (QFN32) 0x8: B<7> (QFN32) 0x9: C<4> (QFN32) 0xa: C<5> (TSSOP16) 0xb: RSVD (pga_p<0> (PGA left-channel positive output)) 0xc: RSVD (pga_p<1> (PGA right-channel positive output)) 0xd: tempsensor_p (Temperature sensor positive output) 0xe: rsvd 0xf: Vbat (Battery voltage)
afe_0xea<3:0>	adc_ain_r_n	00	Select negative input for right channel: 0x0: No input 0x1: B<0> (TSSOP16) 0x2: B<1> (QFN32 & TSSOP16) 0x3: RSVD (B<2>) 0x4: RSVD (B<3>) 0x5: B<4> (QFN32) 0x6: B<5> (QFN32) 0x7: B<6> (QFN32) 0x8: B<7> (QFN32) 0x9: C<4> (QFN32) 0xa: C<5> (TSSOP16) 0xb: RSVD (pga_n<0> (PGA left-channel negative output)) 0xc: RSVD (pga_n<1> (PGA right-channel negative output)) 0xd: tempsensor_n (Temperature sensor negative output) 0xe: Ground 0xf: Ground
afe_0xea<7:4>	adc_ain_r_p	0000	Select positive input for right channel: 0x0: No input 0x1: B<0> (TSSOP16) 0x2: B<1> (QFN32 & TSSOP16) 0x3: RSVD (B<2>) 0x4: RSVD (B<3>) 0x5: B<4> (QFN32) 0x6: B<5> (QFN32) 0x7: B<6> (QFN32) 0x8: B<7> (QFN32) 0x9: C<4> (QFN32) 0xa: C<5> (TSSOP16) 0xb: RSVD (pga_p<0> (PGA left-channel positive output))

Address Decimal	Mnemonic	Default value	Description
			0xc: RSVD (pga_p<1> (PGA right-channel positive output)) 0xd: tempsensor_p (Temperature sensor positive output) 0xe: rsvd 0xf: Vbat (Battery voltage)
afe_0xeb<1:0>	adc_resl	11	Set resolution for left channel 0x0: 8bits 0x1: 10bits 0x2: 12bits 0x3: 14bits
afe_0xeb<3:2>	RSVD		
afe_0xeb<5:4>	adc_resr	11	Set resolution for right channel 0x0: 8bits 0x1: 10bits 0x2: 12bits 0x3: 14bits
afe_0xeb<7:6>	RSVD		
afe_0xec<1:0>	adc_resm	11	Set resolution for Misc channel 0x0: 8bits 0x1: 10bits 0x2: 12bits 0x3: 14bits
afe_0xec<3:2>	RSVD		
afe_0xec<4>	adc_en_diff1	0	Select single-end or differential input mode for left channel. 0: single-ended mode 1: differential mode
afe_0xec<5>	adc_en_diffr	0	Select single-end or differential input mode for right channel. 0: single-ended mode 1: differential mode
afe_0xec<6>	adc_en_diffm	0	Select single-end or differential input mode for Misc channel. 0: single-ended mode 1: differential mode
afe_0xec<7>	RSVD		
afe_0xed<3:0>	adc_tsampl	0000	Number of ADC clock cycles in sampling phase for left channel to stabilize the input before sampling: 0x0: 3 cycles (RNS mode default) 0x1: 6 cycles 0x2: 9 cycles 0x3: 12 cycles ... 0xf: 48 cycles

Address Decimal	Mnemonic	Default value	Description
afe_0xed<7:4>	adc_tsampr	0000	Number of ADC clock cycles in sampling phase for right channel to stabilize the input before sampling: 0x0: 3 cycles (RNS mode default) 0x1: 6 cycles 0x2: 9 cycles 0x3: 12 cycles ... 0xf: 48 cycles
afe_0xee<3:0>	adc_tsampm	0000	Number of ADC clock cycles in sampling phase for Misc channel to stabilize the input before sampling: 0x0: 3 cycles (RNS mode default) 0x1: 6 cycles 0x2: 9 cycles 0x3: 12 cycles ... 0xf: 48 cycles
afe_0xef<7:0>	r_max_mc[7:0]		r_max_mc[9:0] serves to set length of "capture" state for RNS and Misc channel. r_max_c[9:0] serves to set length of "capture" state for left and right channel. r_max_s serves to set length of "set" state for left, right and Misc channel. Note: State length indicates number of 24M clock cycles occupied by the state.
afe_0xf0<7:0>	r_max_c[7:0]		
afe_0xf1<3:0>	r_max_s		
afe_0xf1<5:4>	r_max_c[9:8]		
afe_0xf1<7:6>	r_max_mc[9:8]		
afe_0xf2<0>	r_en_left	0	Enable left channel. 1: enable
afe_0xf2<1>	r_en_right	0	Enable right channel. 1: enable
afe_0xf2<2>	r_en_misc		Enable Misc channel sampling. 1: enable
afe_0xf2<3>	r_en_rns	0	Enable RNS sampling. 1: enable
afe_0xf2<6:4>	r_max_scnt	00	Set total length for sampling state machine (i.e. max state index)
afe_0xf2<7>	rsvd		
afe_0xf3<7:0>	rsvd		
afe_0xf4<2:0>	adc_clk_div	011	ADC clock (derive from external 24M crystal) ADC clock frequency = 24M/(adc_clk_div+1)
afe_0xf4<7:3>	rsvd		
afe_0xf5<7:0>	rng[7:0]		Read only, random number [7:0]
afe_0xf6<7:0>	rng[15:8]		Read only, random number [15:8]
afe_0xf7<7:0>	adc_dat[7:0]		Read only, Misc adc dat[7:0]
afe_0xf8<7:0>	adc_dat[15:8]		Read only [7]: vld, ADC data valid status bit (This bit will be set as 1 at the end of capture state to indicate the ADC data is valid, and will be cleared when set state starts.) [6:0]: Misc adc_dat[14:8]



Address Decimal	Mnemonic	Default value	Description
afe_0xf9<3:2>	adc_vbat_div	00	Vbat divider select (see adc_vref) 0x0: OFF 0x1: VBAT/4 0x2: VBAT/3 0x3: VBAT/2
afe_0xfa<7:6>	adc_sel_ai_scale	0	Analog input pre-scaling select sel_ai_scale[1:0]: scaling factor 0x0: 1 0x1: 1/2 0x2: 1/4 0x3: 1/8
afe_0xfc<4>	adc_mode	0	0: normal mode 1: rsvd (RNS mode)
afe_0xfc<5>	adc_pd	1	Power down ADC 1: Power down 0: Power up

## 10 Temperature Sensor

The TLSR8250F512 integrates a temperature sensor and it's used in combination with the SAR ADC to detect real-time temperature.

The temperature sensor is disabled by default. The analog register `afe_0x07<4>` should be set as 1b'0 to enable the temperature sensor.

Table 10- 1 Analog register for temperature sensor

Address	Name	Description	Default Value
<code>afe_0x07&lt;4&gt;</code>	<code>pd_temp_sensor_3V</code>	Power on/down temperature sensor: 0: Power up 1: Power down	1

The temperature sensor embeds two diodes. It takes the real-time temperature (T) as input, and outputs two-way forward voltage drop ( $V_{BE}$ ) signals of diodes as positive and negative output respectively.

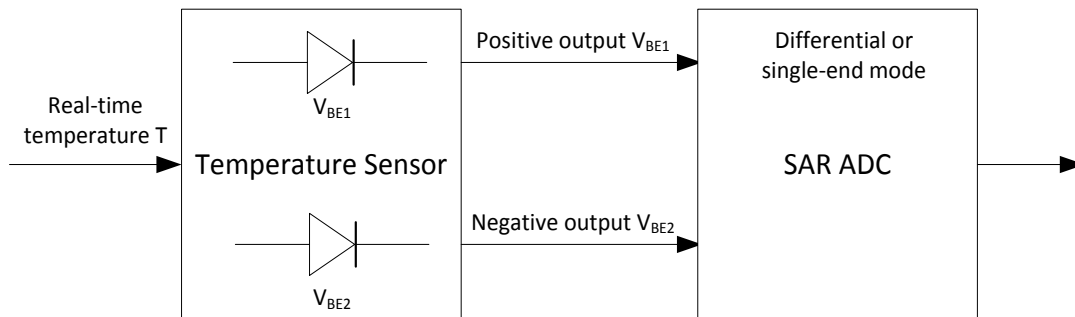

Figure 10- 1 Block diagram of temperature sensor

The difference of the two-way  $V_{BE}$  signals ( $\Delta V_{BE}$ ) is determined by the real-time temperature T, as shown below:

$$\begin{aligned}\Delta V_{BE} &= 130mV + 0.51mV/^{\circ}C * (T - (-40^{\circ}C)) \\ &= 130mV + 0.51mV/^{\circ}C * (T + 40^{\circ}C)\end{aligned}$$

In this formula, "130mV" indicates the value of  $\Delta V_{BE}$  at the temperature of "-40°C".

To detect the temperature, the positive and negative output of the temperature sensor should be enabled as the input channels of the SAR ADC. The ADC will convert the two-way  $V_{BE}$  signals into digital signal.

- ✧ If the ADC is configured as single-end mode, the ADC should initiate two operations, each time the positive/negative output of the temperature sensor should be configured as the single input of the ADC, and two output signals ( $V_1$  and  $V_2$ ) are obtained, therefore,

$$\Delta V_{BE} = \frac{(V_1 - V_2)}{2^N - 1} * V_{REF}$$

In the two formulas, “N” and “ $V_{REF}$ ” indicates the selected resolution and reference voltage of the SAR ADC.

- ✧ If the ADC is configured as differential mode, the positive and negative output of the temperature sensor should be configured as differential input of the ADC. The ADC should initiate one operation and obtain one output signal (ADCOUT), therefore,

$$\Delta V_{BE} = \frac{ADCOUT}{2^N - 1} * V_{REF}.$$

Then the real-time temperature T can be calculated according to the  $\Delta V_{BE}$ .

## 11 AES

The TLSR8250F512 embeds AES module with encryption and decryption function. The input 128bit plaintext in combination of key is converted into the final output ciphertext via encryption; the 128bit ciphertext in combination of key can also be converted into 128bit plaintext via decryption.

The AES hardware accelerator provides automatic encryption and decryption. It only takes (1000\*system clock cycles) to implement AES encryption/decryption. Suppose system clock is 20MHz, the time needed for AES encryption/decryption is 50us.

Both RISC mode and DMA mode are supported for AES operation.

### 11.1 RISC mode

For RISC mode, configuration of related registers is as follows:

- 1) Set the value of key via writing registers AES\_KEY0~ AES\_KEY15 (address 0x550~0x55f).
- 2) Set operation method of AES module via register AES\_CTRL: set address 0x540[0] as 1b'1 for decryption method, while clear this bit for encryption method.
- 3) For encryption method, write registers AES-DAT0~ AES-DAT3 (address 0x548~0x54b) for four times to set the 128bit plaintext. After encryption, the 128bit ciphertext can be obtained by reading address 0x548~0x54b for four times.
- 4) For decryption method, write registers AES-DAT0~ AES-DAT3 (address 0x548~0x54b) for four times to set the 128bit ciphertext. After decryption, the 128bit plaintext can be obtained by reading address 0x548~0x54b for four times.
- 5) Address 0x540 bit[1] and bit[2] are read only bits: bit[1] will be cleared automatically after quartic writing of address 0x548~0x54b; bit[2] will be set as 1 automatically after encryption/decryption, and then cleared automatically after quartic reading of address 0x548~0x54b.

### 11.2 DMA mode

As for DMA mode, it is only needed to configure the value of key and encryption/decryption method for AES module. Please refer to point 1) ~ 2) in section **15.1**.

### 11.3 AES-CCM

The AES-CCM (Counter with the CBC-MAC) mode is disabled by default. AES output is directly determined by current encryption and decryption, irrespective of previous encryption and decryption result.

If 0x540[7] is set as 1b'1 to enable AES-CCM mode, AES output will also take previous encryption and decryption result into consideration.

**11.4 Register table**

Table 11- 1 Register table related to AES

Address	Mnemonic	Type	Description	Reset Value
0x540	AES_CTRL	R/W	[0] Select decrypt/encrypt. 1: decrypt, 0: encrypt [1] Read-only. 1: input data needed, 0: input data ready. [2] Read-only. 0: output data not ready, 1: output data ready. [7] 1: enable AES-CCM mode.	00
0x548	AES-DAT0		Input/Output Data byte 0	
0x549	AES-DAT1		Input/Output Data byte 1	
0x54a	AES-DAT2		Input/Output Data byte 2	
0x54b	AES-DAT3		Input/Output Data byte 3	
0x550	AES_KEY0	R/W	[7:0] KEY0	00
0x551	AES_KEY1	R/W	[7:0] KEY1	00
0x552	AES_KEY2	R/W	[7:0] KEY2	00
0x553	AES_KEY3	R/W	[7:0] KEY3	00
0x554	AES_KEY4	R/W	[7:0] KEY4	00
0x555	AES_KEY5	R/W	[7:0] KEY5	00
0x556	AES_KEY6	R/W	[7:0] KEY6	00
0x557	AES_KEY7	R/W	[7:0] KEY7	00
0x558	AES_KEY8	R/W	[7:0] KEY8	00
0x559	AES_KEY9	R/W	[7:0] KEY9	00
0x55a	AES_KEY10	R/W	[7:0] KEY10	00
0x55b	AES_KEY11	R/W	[7:0] KEY11	00
0x55c	AES_KEY12	R/W	[7:0] KEY12	00
0x55d	AES_KEY13	R/W	[7:0] KEY13	00
0x55e	AES_KEY14	R/W	[7:0] KEY14	00
0x55f	AES_KEY15	R/W	[7:0] KEY15	00

## 12 Key Electrical Specifications

**Note:** The electrical characteristics currently listed in this section are target specifications and only supplied for reference. Some data may be updated according to actual test results.

### 12.1 Absolute maximum ratings

Table 12- 1 Absolute Maximum Ratings

Characteristics	Sym.	Min.	Max	Unit	Test Condition
Supply Voltage	VDD	-0.3	3.6	V	All AVDD, DVDD and VDD_IO pin must have the same voltage
Voltage on Input Pin	V <sub>in</sub>	-0.3	VDD+0.3	V	
Output Voltage	V <sub>Out</sub>	0	VDD	V	
Storage temperature Range	T <sub>Str</sub>	-65	150	°C	
Soldering Temperature	T <sub>Sld</sub>		260	°C	

**CAUTION:** Stresses above those listed in “Absolute Maximum Ratings” may cause permanent damage to the device. This is a stress only rating and operation of the device at these or any other conditions above those indicated in the operational sections of this specification is not implied.

### 12.2 Recommended operating condition

Table 12- 2 Recommended operation condition

Item	Sym.	Min	Typ.	Max	Unit	Condition
Power-supply voltage	VDD <sup>*3</sup>	1.8	3.3	3.6	V	QFN32 package
		2.7	3.3	3.6	V	TSSOP16 package
Supply rise time (from 1.6V to 1.8V)	t <sub>R</sub>			10	ms	QFN32 package
Supply rise time (from 1.6V to 2.8V)				10	ms	TSSOP16 package
Operating Temperature Range	T <sub>Opr</sub>	-40		85	°C	

<sup>3</sup> All AVDD, DVDD and VDD\_IO pin must have the same voltage.

### 12.3 DC characteristics

Table 12- 3 DC characteristics (VDD=3.3V, T=25 °C)

Item	Sym.	Min	Typ.	Max	Unit	Condition
RX current	I <sub>Rx</sub>		5.3		mA	Whole Chip
TX current	I <sub>Tx</sub>		4.8		mA	whole chip @ 0dBm with DCDC
Deep sleep with 8kB SRAM retention	I <sub>Deep1</sub>		1		uA	
Deep sleep with 16kB SRAM retention			1.2		uA	
Deep sleep with 32kB SRAM retention			1.4		uA	
Deep sleep without SRAM retention	I <sub>Deep2</sub>		0.4		uA	

### 12.4 AC characteristics

Table 12- 4 AC Characteristics (VDD=3.3V, T=25 °C)

Item	Sym.	Min	Typ.	Max	Unit	Condition
<b>Digital inputs/outputs</b>						
Input high voltage	V <sub>IH</sub>	0.7VDD		VDD	V	
Input low voltage	V <sub>IL</sub>	VSS		0.3VDD	V	
Output high voltage	V <sub>OH</sub>	0.9VDD		VDD	V	
Output low voltage	V <sub>OL</sub>	VSS		0.1VDD	V	
<b>RF performance</b>						
Item		Min	Typ	Max	Unit	
RF frequency range		2380		2500	MHz	Programmable in 1MHz step
Data rate	BLE 1Mbps, ±250kHz deviation					
<b>BLE 1Mbps RF_Rx performance (±250kHz deviation)*4</b>						
Sensitivity	1Mbps		-96		dBm	
Frequency Offset Tolerance		-250		+300	kHz	
Co-channel rejection			-11		dB	Wanted signal at -67dBm
In-band blocking rejection (Equal Modulation Interference)	+1/-1 MHz offset		1/3		dB	Wanted signal at -67dBm
	+2/-2 MHz offset		37/39		dB	

<sup>4</sup> For actual sensitivity level of BLE 1Mbps mode, please refer to Bluetooth 5 specification.

Item	Sym.	Min	Typ.	Max	Unit	Condition
	$\geq 3$ MHz offset		42		dB	
Image rejection			37		dB	Wanted signal at -67dBm
<b>BLE 1Mbps RF_Tx performance</b>						
Output power, maximum setting			10		dBm	
Output power, minimum setting			-45		dBm	
Programmable output power range		55			dB	
Modulation 20dB bandwidth			2.5		MHz	
<b>RSSI</b>						
RSSI range		-100		10	dBm	
Resolution			1		dB	
<b>24MHz crystal</b>						
Nominal frequency (parallel resonant)	$f_{NOM}$		24		MHz	
Frequency tolerance	$f_{TOL}$	-20		+20	ppm	
Load capacitance	$C_L$	5	12	18	pF	Programmable on chip load cap
Equivalent series resistance	ESR		50	100	ohm	
<b>32.768kHz crystal (only for TLSR8250F512ET32)</b>						
Nominal frequency (parallel resonant)	$f_{NOM}$		32.768		kHz	
Frequency tolerance	$f_{TOL}$	-100		+100	ppm	
Load capacitance	$C_L$	6	9	12.5	pF	Programmable on chip load cap
Equivalent series resistance	ESR		50	80	kohm	
<b>24MHz RC oscillator</b>						
Nominal frequency	$f_{NOM}$		24		MHz	
Frequency tolerance	$f_{TOL}$		1		%	On chip calibration
<b>32kHz RC oscillator</b>						
Nominal frequency	$f_{NOM}$		32		kHz	
Frequency tolerance	$f_{TOL}$		0.03		%	On chip calibration
Calibration time			3		ms	



Item	Sym.	Min	Typ.	Max	Unit	Condition
<b>ADC</b>						
Differential nonlinearity	DNL			1	LSB	10bit resolution mode
Integral nonlinearity	INL			2	LSB	10bit resolution mode
Signal-to-noise and distortion ratio	SINAD		70		dB	$f_{in}=1\text{kHz}$ , $f_s=16\text{kHz}$
Effective Number of Bits	ENOB		10.5		bits	
Sampling frequency	$F_s$			200	ksps	

**12.5 SPI characteristics**

Table 12- 5 SPI characteristics

(over process, voltage 1.9~3.6V, and T=-40~+85°C)

Item	Sym.	Min	Typ.	Max	Unit	Condition
CK frequency	F <sub>CK</sub>			4	MHz	Slave
CK duty cycle clock			50		%	Master
DI setup time		30			ns	Slave
		90			ns	Master
DI hold time		10			ns	Slave
		90			ns	Master
CK low to DO valid time				30	ns	Slave
				120	ns	Master
CN setup time		60			ns	Master/Slave
CN high to DI tri-state* <sup>5</sup>					ns	Master

<sup>5</sup> Note: Master actively stops reading during transmission, and Slave releases its driver DO and turns to tri-state.

**12.6 I2C characteristics**

Table 12- 6 I2C characteristics

(over process, voltage 1.9~3.6V, and T=-40~+85°C)

Item	Sym.	Standard mode		Fast mode		Unit	Condition
		Min	Max	Min	Max		
SCL frequency	$F_{SCL}$		100		400	kHz	
Rise time of SDA and SCL signals	$T_R$		1000		300	ns	
Fall time of SDA and SCL signals	$T_F$		300		300	ns	
START condition hold time	$T_{HD;STA}$	4		0.6		us	
Data hold time	$T_{HD;DAT}$	0	3.45		0.9	us	
Data setup time	$T_{SU;DAT}$	250		100		ns	
STOP condition setup time	$T_{SU;STO}$	4		0.6		us	

## 12.7 Flash characteristics

Table 12- 7 Flash memory characteristics for QFN32 package

(T= -40°C~85°C)

Item	Sym.	Min	Typ.	Max	Unit	Condition
Retention period		20			year	
Number of erase cycles		100k			cycle	
VDD for programming		1.65		2.0	V	Note this refers to the SoC supply
Sector size			4		kB	
Page programming time	TPP		1.6	6	ms	
Sector erase time	TSE		150	500	ms	
Block erase time (32kB/64kB)	TBE		0.5/0.8	2.0/3.0	s	
Program current	I <sub>p</sub>			10	mA	
Erase current	I <sub>E</sub>			10	mA	

Table 12- 8 Flash memory characteristics for TSSOP16 package

(T= -40°C~85°C)

Item	Sym.	Min	Typ.	Max	Unit	Condition
Retention period		20			year	
Number of erase cycles		100k			cycle	
VDD for programming		2.7		3.6	V	Note this refers to the SoC supply
Sector size			4		kB	
Page programming time	T <sub>PP</sub>		0.7	4	ms	
Sector erase time	T <sub>SE</sub>		100	400	ms	
Block erase time (32kB/64kB)	T <sub>BE</sub>		0.3/0.5	1.2/2.0	s	
Program current	I <sub>P</sub>			20	mA	
Erase current	I <sub>E</sub>			20	mA	

### 13 Reference Design

#### 13.1 Application example for TLSR8250F512ET32

##### 13.1.1 Schematic

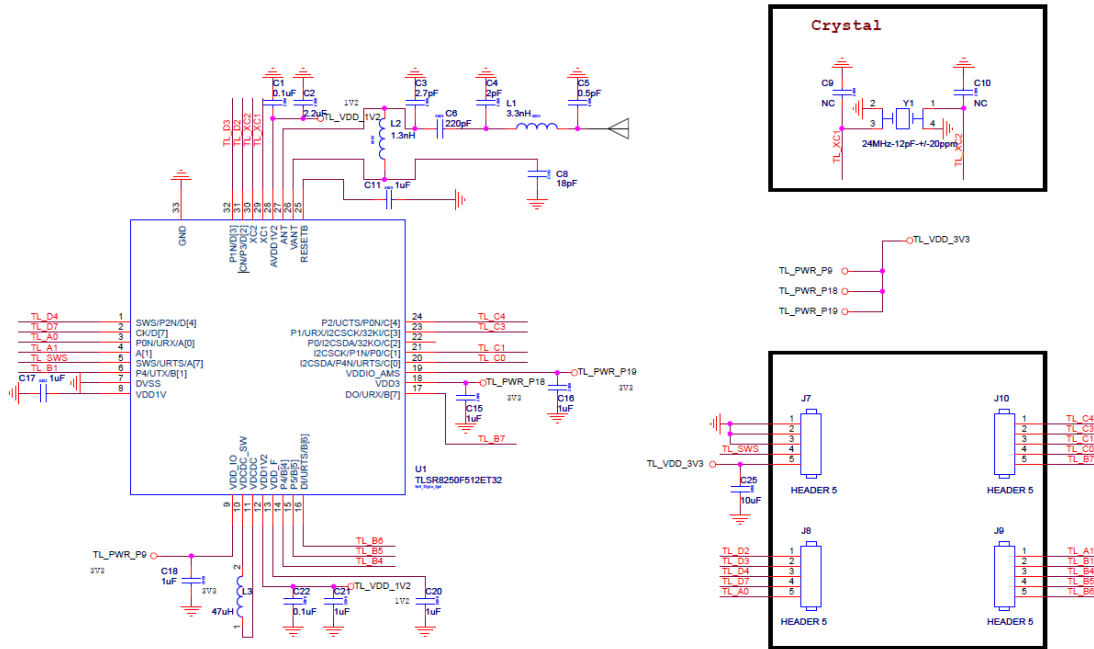

Figure 17- 1 Schematic for TLSR8250F512ET32

##### 13.1.2 BOM (Bill of Material)

Table 17- 1 BOM table for TLSR8250F512ET32

Quantity	Reference	Part	PCB Footprint
2	C1,C22	0.1uF	0402
1	C3	2.7pF	0402
1	C4	2pF	0402
1	C5	0.5pF	0402
1	C6	220pF	0402
1	C8	18pF	0402
7	C11,C15,C16,C17,C18,C20,C21	1uF	0402
1	C2	2.2uF	0402
1	C25	10uF	0603
1	L1	3.3nH	0402
1	L2	1.3nH	0402
1	L3	47uH	0805
1	U1	TLSR8250F512ET32	qfn_5x5_32pin_0p5_2p50x2p50
1	Y1	24MHz_12pF_+/-20ppm	OSCCC250X320X110

### 13.2 Application example for TLSR8250F512ES16

#### 13.2.1 Schematic

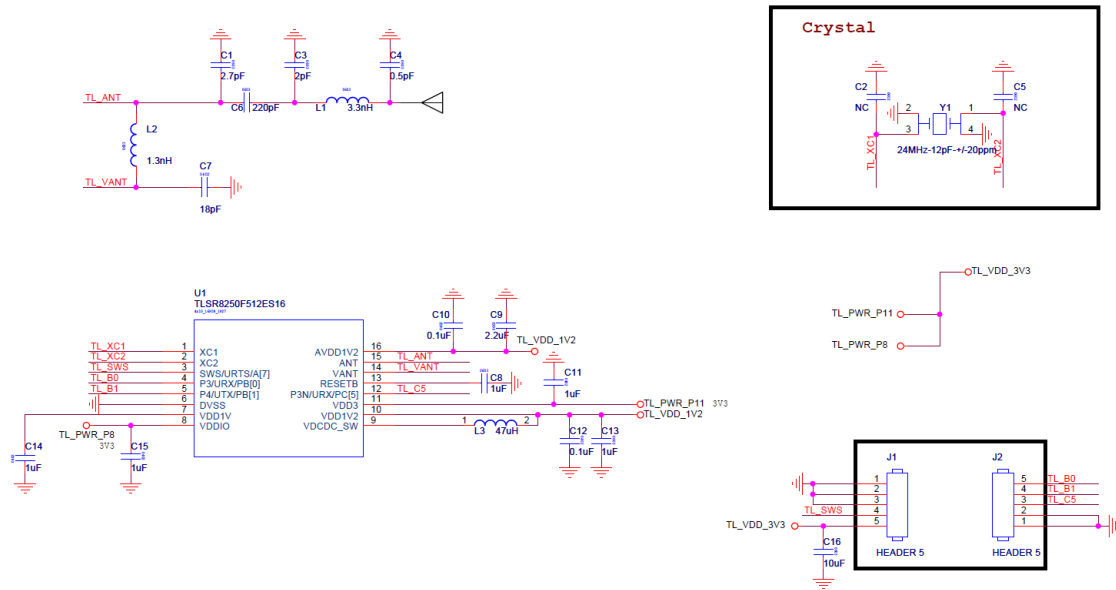

Figure 17- 2 Schematic for TLSR8250F512ES16

**13.2.2 BOM (Bill of Material)**

Table 17- 2 BOM table for TLSR8250F512ES16

Quantity	Reference	Part
1	C1	2.7pF
2	C2	NC
	C5	NC
1	C3	2pF
1	C4	0.5pF
1	C6	220pF
1	C7	18pF
5	C8	1uF
	C11	1uF
	C13	1uF
	C14	1uF
	C15	1uF
1	C9	2.2uF
2	C10	0.1uF
	C12	0.1uF
1	C16	10uF
1	L1	3.3nH
1	L2	1.3nH
1	L3	47uH
1	U1	TLSR8250F512ES16
1	Y1	24MHz_12pF_+/-20ppm